

Original instructions

ENG 0/20

OPERATOR'S MANUAL

OMR03PXENG.020

**Ram
mer®**

HYDRAULIC HAMMER

RAMMER R03P

R A M M E R H I T S H A R D E R

OPERATION	3
1. Introduction	4
2. Safety and environmental instructions. . .	9
3. Safety section	27
4. Safety during operation.	38
5. Transportation, storage and setting up .	45
6. Hammer installation and removal.	48
7. Operation	51
LUBRICATION	65
1. Greasing the hammer	66
2. Hydraulic oil.	68
MAINTENANCE	69
1. Routine maintenance	70
2. Releasing pressure from the hammer. . .	73
3. Checking pressure in the low pressure accumulator.	74
4. Recharging the low pressure accumulator.	78
5. Changing the tool	82
6. Changing the lower tool bushing	87
7. Troubleshooting	88
SPECIFICATIONS	93
1. Hammer specifications	94
2. Tool specifications	98
3. CE mark and EC Declaration of Conformity	99

OPERATION

1. INTRODUCTION

1.1 THIS MANUAL

BG: Поискайте от дистрибутора на Rammer версия на български език на това ръководство.
 CS: Českou/Slovenskou verzi této příručky získáte o vašeho prodejce společnosti Rammer.
 DA: Bed om en dansksproget version af denne manual hos din Rammer-forhandler.
 DE: Fragen Sie Ihren Rammer-Händler nach der deutschen Fassung dieses Handbuchs.
 EL: Ζητήστε την ελληνική έκδοση του παρόντος εγχειριδίου από τον τοπικό αντιπρόσωπο της Rammer.
 EN: Ask for the English language version of this manual from your Rammer dealer.
 ES: Pídale a su distribuidor de Rammer la versión en español de este manual.
 ET: Käesoleva kasutusjuhendi eestikeelse versiooni saate Rammer i edasimüüjal.
 FI: Pyydä suomenkielinen ohjekirja Rammer-jälleenmyyjältäsi.
 FR: Adressez-vous à votre revendeur Rammer pour obtenir la version française de ce manuel.
 HR: Hrvatsku verziju ovog priručnika zatražite od zastupnika tvrtke Rammer.
 HU: Ez a kézikönyv magyar nyelven is elérhető, kérje Rammer forgalmazójától.
 IS: Biðjið Rammer dreifingaraðila ykkar um íslenska útgáfu af þessari handbók.
 IT: È possibile richiedere la versione in lingua italiana di questo manuale presso il rivenditore Rammer.
 LT: Paprašykite savo Rammer platintojo lietuviškos instrukcijos versijos.
 LV: Rokasgrāmatas tulkojumu latviešu valodā jautājiem savam Rammer dīlerim.
 NL: Vraag bij uw Rammer-dealer naar de Nederlandse versie van deze gebruiksaanwijzing.
 NO: Be om den norske versjonen av denne håndboken fra din Rammer-leverandør.
 PL: Proszę zwrócić się do dystrybutora Rammer, aby otrzymać niniejszą instrukcję w języku polskim.
 PT: Solicite a versão em português deste manual ao seu representante Rammer.
 RO: Solicitați versiunea în limba română a acestui manual de la distribuitorul dumneavoastră Rammer.
 RU: Запросите версию данного руководства на русском языке у вашего дилера компании Rammer.
 SK: Českú/Slovenskú verziu tejto príručky získate u svojho predajcu spoločnosti Rammer.
 SL: Vprašanje svojega Rammer predstavnika za ta priročnik v slovenskem jeziku.
 SR: Tražite verziju ovog priručnika na srpskom jeziku od vašeg Rammer dilera.
 SV: Be om den svenskspråkiga versionen av denna manual hos din Rammer-återförsäljare.
 TR: Bu kılavuzun Türkçe versiyonunu Rammer temsilcinizden isteyebilirsiniz.

BA010041

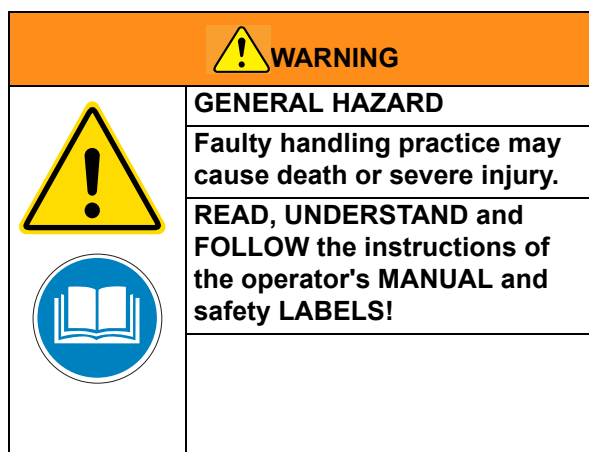

Information for use consists of this manual, the safety labels on the machinery, the carrier manual and other information for proper and safe use of this machinery.

Instructions are an essential and integral part of the product. Always keep them available for users.

Store this manual in the operator's compartment in the literature holder or seat back literature storage area for easy user access at any time.

Keep all information for use clean and in good condition. If necessary, ask for a translation of information for use.

The related safety label on the hammer and the text on the label are shown below.

"IGNORING INSTRUCTIONS HAZARD

Faulty handling practice could cause death or severe injury.

Read and follow the instructions in the operator's manual."

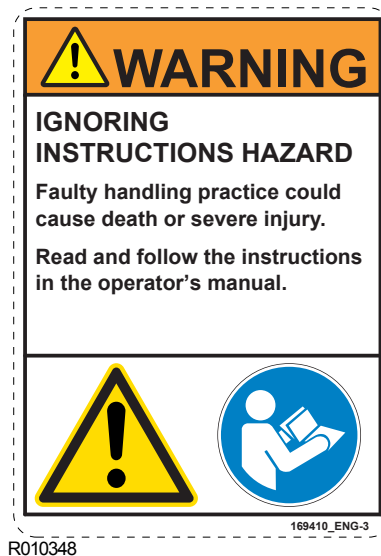

1.2 THE PURPOSE OF INSTRUCTIONS

The purpose of these instructions is to promote intended safe, proper and economical use of this hammer. These instructions assist the user in identifying, avoiding and preventing hazardous situations and related consequences.

Always follow these instructions along with any instructions given in local laws and regulations, any orders given by local authorities and all protective measures specific for the site (such as safe working procedures).

Read and understand the complete information for use carefully, and follow given instructions strictly. If there is anything you don't understand, ask your employer or your Rammer representative to explain. All sections of this manual contain information which is vital for your safety.

Replace the operator's manual immediately if lost, damaged or unreadable. For replacement copies, contact your Rammer representative.

Use the instructions set forth in the information for use as a part of the training material during orientation. Following these instructions helps minimize maintenance cost and downtime, and optimize reliability and life of the product.

1.3 IDENTIFICATION

The model and serial number are shown on the serial number plate. Check that the model corresponds to the one given on the cover of this manual.

It is important to make correct reference to the serial number of the hammer, when making repairs or ordering spare parts. Identification of the serial number is the only proper means of maintaining and identifying parts for a specific hammer.

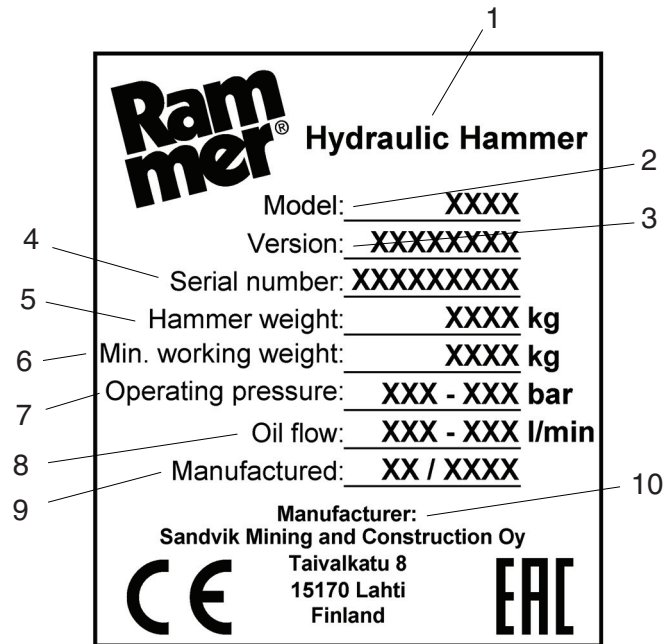

BA010062

CONTENT OF THE PRODUCT IDENTIFICATION PLATE

1	Hydraulic Hammer
2	Model
3	Version
4	Serial Number
5	Hammer weight (kg)
6	Min working weight (kg)
7	Operating pressure (bar)
8	Oil flow (l/min)
9	Manufactured or Manufacturing date
10	Manufacturer

1.4 MANUFACTURER

This hydraulic hammer has been manufactured by:

Sandvik Mining and Construction Oy, Breakers Lahti, Taivalkatu 8, FI - 15170 Lahti, Finland.

For maintenance and service of this hydraulic hammer contact your nearest Rammer representative. Dealer and distributor information may be found at www.rammer.com.

1.5 CE MARK AND EC DECLARATION OF CONFORMITY

The CE mark is located on the serial number plate of the hammer. See “CE mark and EC Declaration of Conformity” on page 99.

1.6 VALIDITY OF MANUAL

This manual contains safety information, operation instructions, transportation information, lubrication information and maintenance information in accordance with the hydraulic hammer design at the time it was delivered from factory.

This manual, and especially its safety information as well as the EC declaration of conformity and statement of compliance, are valid only, if no unauthorized changes to the product are made.

Some illustrations in this publication show details that can be different from your hammer. Guards and covers may have been removed for illustrative purposes.

Continuing improvement and advancement of product design may have caused changes to your hammer, which are not included in this publication.

Whenever a question arises regarding your hammer, or this manual, please consult your dealer for the latest available information.

1.7 COPYRIGHT NOTICE

This publication is copyright of Sandvik Mining and Construction Oy, Breakers Lahti, Finland.

© Sandvik Mining and Construction Oy, Breakers Lahti, Finland 2020.

It must not be copied, reproduced, or otherwise made available in full or in part to any third party without our prior written consent.

All Rights Reserved.

1.8 DEFINITIONS

Hammer - the product described in this manual.

Tool - the wear part which is in direct contact with the rock.

Carrier - the base machine, onto which the hammer is mounted, and which supplies the operating power and controls, with which the hammer is operated.

This Manual - this one complete book, which contains vital information for transportation, handling and storage as well as installation, operation and maintenance of the hammer.

Safety Label - label applied on the hammer advising on protective measures for the most severe risks.

Information for Use - the information in this manual, the safety labels on hammer and other information on, for example, the delivery package. This provides protective measures and advice on proper methods for transportation, installation, operation and maintenance of the hammer.

Intended Use - use of this hammer in accordance with the instructions provided in information for use.

Prohibited Use - any use of this hammer, which is not intended use. Especially the use which is specifically prohibited in information for use.

Reasonably Foreseeable Misuse - use of the hammer in a way not intended, but which may result from readily predictable human behaviour.

User - any person handling the hammer, whether it be transportation, installation, operation, scheduled maintenance, scrapping or other.

Harm - physical injury or damage to health. This is always in relationship to people, not to equipment or property.

Hazard - potential source of harm.

Risk - the combination of the probability of occurrence of harm and the severity of that harm.

Protective Measure - the measure intended to achieve risk reduction. The protective measures are implemented by the designer where possible, and by the user, where design measures are not sufficient for safe operation.

Protective measures for the user are given in the information for use.

User Obligations - protective measures, which must be taken by the user based on the information for use.

Hazard Zone - any space around the hammer or the carrier, in which a person can be exposed to a hazard.

Bystander - any person in hazard zone, who is not handling the hammer.

Real Time Hazard Analysis (RTHA) - review of site before starting to work, in order to identify potential hazards that could impact users, bystanders or environment.

2. SAFETY AND ENVIRONMENTAL INSTRUCTIONS

Safety is the result of attitude. Proper attitude includes:

- Realize the hazards related to what you do, whether it be operation or maintenance. Don't ever take hazards lightly.
- Follow all local laws and regulations. Leave special work to the specialist.

Special conditions, such as radioactive, asbestos, chemical, poisonous or biological hazard environment require unconditional use of hazard specific methods and protective measures.

- Read, understand and follow the instructions of this manual! Read, understand and follow the instructions of carrier manual! If this language version is not proper, ask for a translation of this manual.
- Communicate! Tell other people what you are about to do, so that they do not place you or themselves at risk. Installation or other maintenance related work must never be done alone.

Always keep people informed of what you are doing when and where. Keep mobile phone always at hand. Advise site manager, when you leave site.

Agree with your colleagues on site on the use of hand signals. Do not assume any knowledge of signals.

- Wear approved PPE (approved safety boots, approved safety gloves, approved safety glasses, approved ear protection, approved hard hat). If your PPE is not functioning properly, get new PPE equipment. Only operate the product when in fit condition. Beware of sharp edges of parts.
- Common sense is the most important part of safety in standard hammer applications.

2.1 SAFETY LABELS

This section includes explanations of safety symbols and labels used on the hammer and in information for use.

SIGNAL WORDS

The following signal words and symbols are used to identify safety messages in these instructions:

The signal word "DANGER" in white font on red background together with a safety alert symbol indicates a hazardous situation which, if not avoided, will result in death or serious injury.



D010097

The signal word "WARNING" in black font on orange background together with a safety alert symbol indicates a hazardous situation which, if not avoided, could result in death or serious injury.



D010098

The signal word "NOTICE" indicates a situation which, if not avoided, could result in damage to property or environment. A "NOTICE" situation will not involve a specific hazard to people.



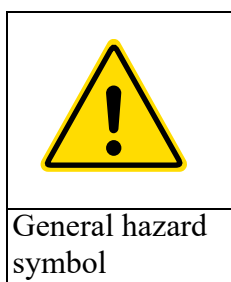

GENERAL SAFETY SYMBOL

This general safety symbol identifies important safety messages in this manual. When you see this symbol, be alert; your safety is involved. Carefully read and understand the message that follows, and inform other users.



SYMBOLS FOR MANDATORY ACTIONS



Mandatory Actions are indicated by white symbols on a blue background. Mandatory action symbols specify the action, which **must** be taken to eliminate a hazard pointed out in the hazard symbol.

			
Read the Manual. It is mandatory to read operator's manual.	Pin-Hole Leakage. Testing for leak of pressurized fluid must always involve a test piece (cardboard or similar).	Keep Safety Distance. Mandatory to keep safety distance from equipment.	Read Workshop Manual. Mandatory to read workshop instructions for safe practice and proper product settings.

SYMBOLS FOR PROHIBITED ACTIONS

Prohibited Actions are indicated by a red circle with a red diagonal line across the circle. The action which is prohibited is always in black.

Prohibited action symbols advise on the action, which **must** be avoided. This is not a matter of choice or judgement, but an indisputable instruction.



	
Pin Hole Hazard. Do not use hand for testing hydraulic leaks!	Hazard Zone. Prohibited to be in hazard zone. Keep Out!



PERSONAL PROTECTIVE EQUIPMENT (PPE) SYMBOLS



Personal Protective Equipment (PPE) symbols have the same layout as mandatory action symbols and are mandatory where applicable.

PPE symbols specify the protective measure, which **must** be taken to eliminate a hazard pointed out in the safety message.

This is not a matter of choice or judgement, but an indisputable instruction.



	
<p>Wear Approved Respirator. Wearing an approved respirator is mandatory in equipment operation.</p>	<p>Wear Approved Ear Protection. Approved ear protection is mandatory in equipment handling.</p>



	
<p>Wear Approved Hard Hat. Approved hard hat is mandatory in equipment handling.</p>	<p>Wear Approved Safety Boots. Approved safety boots are mandatory in equipment handling.</p>



	
Wear Approved Safety Gloves. Approved safety gloves are mandatory in equipment handling.	Wear Approved Eye Protection. Approved safety glasses are mandatory in equipment handling.

HAZARD SYMBOLS

Hazard symbols indicate the nature of a possible hazard. Hazard symbols are indicated by a yellow triangle with black symbols and black frames.

	
General Hazard. This symbol is used where the hazard is not easily specified.	Airborne Pollution. Hazard related to inhalation of silica dust, as well as fumes or other hazardous substances.

	
Hanging Loads. Hazard related to lifting of equipment or parts during transportation, service or other working phases.	Flying Fragments. Hazard related to flying fragments of rock or other debris during operation, maintenance, washing or other.

	
<p>High Pressure. Hazard related to pressurized parts or product.</p>	<p>Crushing. Hazard related to crushing due to e.g. moving product.</p>

<p>Crushing of Hands. Hazard related to crushing of hand.</p>

LABELS ON THE PRODUCT

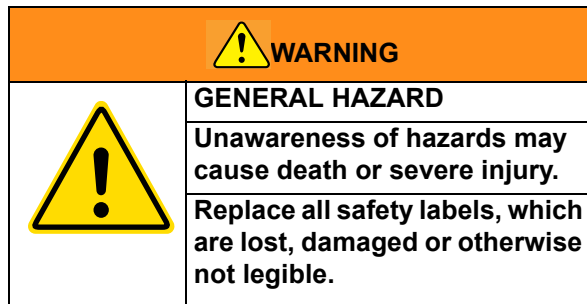

Safety labels communicate the following four things:

- The severity level of the risk (with the signal word "DANGER" or "WARNING").
- The nature of the hazard (that is the type of hazard: high pressure, dust...).
- The consequence of interaction with the hazard.
- How to avoid the hazard.

You must ALWAYS follow the instructions of the safety messages and symbols of the product safety labels and the instructions set forth in the manuals to avoid death or severe injury!

Keep the safety labels clean and visible at all times. Check the condition of safety labels daily. Safety labels and instructions which have disappeared, been damaged, painted over, come loose or do not meet the legibility requirements for safe viewing distance, must be replaced before operating the product.

If a safety label is attached to a part that is replaced, install a new safety label on the replacement part. If this manual is available in your language, then the safety labels should be available in the same language.

There are several specific safety labels on this hammer. Please become familiarized with all safety labels. The location of the safety labels is shown in the illustration below.

When you clean the safety labels, use a cloth, water and soap. Do not use solvent, gasoline or other harsh chemicals to clean the safety labels.

Solvents, gasoline or harsh chemicals could loosen the adhesive that secures the safety labels. Loose adhesive will allow the safety label to fall.

! DANGER
DUST HAZARD
 Breathing dust will cause death or severe injury.
 Always wear approved respirator.

! WARNING
NOISE HAZARD
 Continuous exposure to noise above 80 dB(A) could cause hearing impairment.
 Wear approved hearing protectors.

! WARNING
IGNORING INSTRUCTIONS HAZARD
 Faulty handling practice could cause death or severe injury.
 Read and follow the instructions in the operator's manual.

! DANGER
HIGH PRESSURE HAZARD
 Improper handling of pressurized accumulator will cause death or severe injury.
 Read workshop manual before disassembly.
 Release pressure before disassembly.
 Recharge with nitrogen (N₂) only.

! WARNING
FLYING OBJECTS HAZARD
 Fragments fly up to 40 m (130 ft) and could cause death or severe injury.
 Stop operation when a person enters hazard zone.
 Wear approved personal protective equipment.

Rammer Hydraulic Hammer
 Model: XXXX
 Version: XXXXXXXX
 Serial number: XXXXXXXX
 Hammer weight: XXXX kg
 Min. working weight: XXXX kg
 Operating pressure: XXX - XXX bar
 Oil flow: XXX - XXX l/min
 Manufactured: XX / XXXX



Manufacturer:
 Sandvik Mining and Construction Oy
 Taivalkatu 8
 15170 Lahti
 Finland

CE EAC

LWA
 XX dB

BA010065

2.2 USER OBLIGATIONS

 WARNING	
	GENERAL HAZARD
	Improper installation, operation or maintenance could cause death or severe injury!
	This product may be used or maintained only by a person who has received proper training and has demonstrated that he or she has the competence and the skills needed for safe and proper operation or maintenance.

The safe use of a product depends on, among other things, a combination of design and construction measures taken by the manufacturer, skills of operators and protective measures taken by the user.

It is important to pass the information for use on to any subsequent user of this hammer.

Rammer prohibits, in connection with the access to the hammer, the consumption, possession and distribution of:

- intoxicants and narcotics
- any kind of legal or illegal drugs
- items which are in conjunction with any of these
- firearms and unapproved explosives



WARNING!

Only operate the product when in fit condition. Do not handle the product in intoxicated condition (alcohol, drugs), tired or otherwise unfit condition (fever or illness).

Safety information covers transport, installation, use, settings, operation, cleaning, troubleshooting, maintenance and disposal of machinery. Safe working procedures are needed for each phase.

In case you need more detailed instructions, do not hesitate to contact your Rammer representative.

Protective measures, which must be taken by the user, based on the information for use:

- Use of personal protective equipment (PPE).
- Provision and use of additional safeguards.

Use vertical steel bars, separate plastic net or plastic window for operator cab protection.

- Regular training on site safety and safe working procedures.

Other particular issues which should be known to the user are:

- Site organization and supervision.
- Workplace safety, including safe working procedures.
- Permit-to-work systems.

All near-miss incidents and accidents must be reported to Rammer without delay, where a Rammer hammer has been involved.

The following safety guidelines apply for each person working with the hammer or in the vicinity of the hammer:

- Every single person is responsible for their own safety and for the safety of her or his colleagues.
- In case of violation of any safety guidelines or regulations, every single person is responsible to warn the others and the responsible supervisor.



WARNING!

Authorized spare parts are listed on a spare parts list. Use of non-authorized spare parts may cause an uncontrolled risk to user health and is thus prohibited.

MANAGING WORK-RELATED HAZARDS

All mechanical equipment can be hazardous if handled without due care or correct maintenance. Most accidents involving equipment handling are caused by failure to observe basic safety rules or precautions.

Because it is impossible to anticipate every possible circumstance that might involve a potential hazard, the warnings in this manual and on the equipment are not all inclusive.

Safety is not just a matter of responding to the warnings. All the time you are working with your attachment you must pay attention to the hazards there might be and how to avoid them.

The user must always perform a local risk assessment before starting a task. This assessment, also known as a Real Time Hazard Analysis, ensures that the user stops and thinks about what she or he is going to do before starting to work:

- Perform Real Time Hazard Analysis on site at least daily before starting up. Determine escape route for emergency situation.
- Identify potential hazards that could impact you, your colleague, the environment, your product and/or work method while you are performing the task.
- Assess the risks and implement the actions needed to eliminate or reduce the risk.
- Make sure that you do not damage or make the product unsafe by the method of operation or maintenance you choose.

Review site before using the hammer. Heavy load of equipment or vibration of hammer work may cause structures (walls, roofing, bridges, floors) to collapse. Keep yourself and bystanders out of hazard zone.

**WARNING!**

This hammer may be operated or maintained only by a person who has received proper training and has demonstrated that he or she has the skills needed for safe and proper operation or maintenance.

Only competent persons may carry out operation and other tasks. The employer must:

- Provide training and orientation.
- Validate training methods.
- Verify competence and skills.
- Monitor and evaluate user performance regularly.

**WARNING!**

This hammer is for professional use only. Especially in equipment rental applications the renting company must make sure that the user has demonstrated the necessary skills and knowledge for safe and proper operation and maintenance of both carrier and hammer.

WORKSHOP SERVICE

Workshop service (disassembly/assembly) of this hammer should be performed by trained and authorized personnel. Please consult your nearest Rammer dealer or distributor for further information.

NATIONAL SAFETY REGULATIONS

It is the responsibility of the user to follow national safety regulations at all time. Special care should be given to dust, noise and vibration related regulation.

Ignorance is no excuse for not following national law. Familiarize yourself with the national safety legislation.

SITE SPECIFIC SAFETY REGULATIONS

Site specific regulations must not contradict national safety regulations. Site specific regulations should address issues like transportation of product or equipment, access to site, personal protective equipment (PPE) and working hours.

Site specific regulations should also cover the case of an incident occurring: what to do, who to contact and other questions.

Site specific regulations must be followed at all time in the same way as national safety regulations.

PERIODIC SAFETY INSPECTIONS

It is important to thoroughly inspect the product before use, to make sure it is safe to operate. Look for defects and damage before any operation so that problems can be reported and fixed.

The operator is responsible to:

- Check the product in accordance with the requirements of the operator's manual before, during and after use and operation.
- Safety features, such as labels, safeguards and others should be checked frequently and repaired immediately, if damaged.

Respiratory silica dust is a hazard, which requires special attention. Regularly clean your working environment properly to minimize the dust level in the air.









PERIODIC MAINTENANCE

Periodic maintenance is an essential procedure to ensure and maintain safety and performance of the product. Follow given instructions for maintenance and inspection of the product.

Regular inspections are especially important where hydraulic hoses are concerned.

NOTICE! Poor quality of hydraulic oil, lack of lubrication or too wide clearance between tool and tool bushing may destroy internal parts of the product.

PERSONAL PROTECTIVE EQUIPMENT (PPE)

 WARNING	
      	GENERAL HAZARD
	Lack of approved PPE may cause severe injury or death.
	Wear approved PPE (approved respirator, approved hard hat, approved ear protection, approved safety boots, approved safety gloves, approved safety glasses)

Operators and anyone in the vicinity of the product **MUST** wear approved personal protective equipment (PPE).

Proper PPE includes (but is not restricted to):

- Approved ear protection
- Approved respiratory protection
- Approved eye protection
- Approved safety boots
- Approved hard hat
- Approved protective gloves
- Approved high visibility vest

Do not wear loose clothing or jewelry that can snag on controls or on other parts of the equipment. Confine long hair.

Special conditions may require the use of additional PPE as specified in safe working procedures.

2.3 INTENDED USE

Intended use of machinery

This hydraulic hammer is to be used as an attachment on a carrier in demolition, trenching, quarrying or mining applications.

Designed environmental conditions

This hammer is designed to operate in standard environmental conditions with the following restrictions:

- The ambient temperature for use of hammer is -20 °C ... +80 °C.
- **WARNING! Use of hammer in explosive atmosphere (gasoline fumes, coal dust...) is strictly prohibited.** The tool in contact with the material to be broken will create sparks, which could ignite an explosive atmosphere.

Properties of the materials to be processed

This hammer reduces the fragment size of concrete, rock, hard or frozen ground, asphalt, metallurgical slag or similar material and has been designed exclusively for this application.



WARNING!

Special conditions with, for example, radioactive, asbestos, chemical, poison or biological hazards require unconditional use of hazard specific methods and protective measures.

Under such special conditions, methods and precautions must be reviewed in co-operation with the local and national authorities. Operation may only commence when approval has been granted.

Prohibited use of machinery

Any use of this hammer not permitted as intended use, outside the designed environmental conditions or on unsuitable materials to be processed, is prohibited.

Use of this hammer is specifically prohibited if:

- Operator has not read and understood this manual.
- Operator has not read and understood operator's manual for the carrier.
- A safety feature of the equipment is defeated for whatever reason.
- Operator has not performed Real Time Hazard Analysis (RTHA) of the site and is not aware of escape route for emergency situation.
- Operator is without proper and approved personal protective equipment.
- People are in hazard zone of hammer.
- Hammer is outside the technical limits as described in the technical specification. This applies especially to carrier weight, hydraulic oil pressure and oil flow.

**WARNING!**

Hammer or lifting eye on hammer must not be used to lift external loads.

**WARNING!**

Hammer must not be used in intoxicated condition (alcohol, drugs), when tired or when otherwise in unfit condition (fever or illness).

Foreseeable misuse

Foreseeable misuse may be due to carelessness or to pressure to keep product running at any time.

Reasonably foreseeable misuse is extremely likely to cause considerable damage to people or property. Examples of such behavior are:

- Operating the product outside limits of use: Do not use the product on carrier with insufficient lifting capacity! Do not operate the product under water! Do not operate the product outside other limits of use.
- Always perform site and equipment inspection before operation (RTHA).
- Non-professional operation: Do not operate equipment without proper training. Do not operate, if you are not in fit condition.
- Operating broken equipment: **NOTICE! Stop immediately, when you observe failure on structures or hydraulic leak!**

Foreseeable misuse is not an acceptable excuse to cause considerable damage to equipment, environment or people.

Liability

Rammer will not accept any liability for injury to personnel or damage to equipment caused by unauthorized use, negligence of user obligations or unauthorized modification of this hammer.

2.4 MODIFICATIONS AND CORRECTIONS TO THE PRODUCT

All modifications and corrections not authorized in the maintenance manuals or which may affect the maintenance, operation, safety, and availability of the product need to be approved in writing by the manufacturer before implementation. Approval requires a careful risk assessment, taking into consideration the known risks and any new risks that the modifications may cause.

Changes and modifications without proper risk assessment, elimination or reduction of risk and without appropriate safety measures may lead to death, serious personal injuries or damage to property.



Unauthorized modifications may add additional weight to the equipment. This may affect stability during lifting and stability of the carrier. Unauthorized modifications may disable safety features and must not be applied.

If modifications and corrections that affect the maintenance, operation, safety, and usability of the product are made without the written permission of the manufacturer, the manufacturer is not responsible for any incidents resulting in death, injury, or property damage brought about by such modifications and corrections.

Should you consider a modification or correction necessary, please ask your local dealer to contact the manufacturing and design team of the equipment.

If a modification or correction as described above has been implemented without the manufacturing factory's permission, its effect on warranty liability will be considered case-by-case. Thus, a warranty application may be rejected altogether.

2.5 HAZARD ZONE

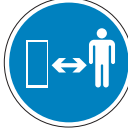
 DANGER	
	DANGER ZONE: CRUSHING HAZARD
	Getting caught by machinery movement may cause severe injury or death. Keep yourself and bystanders out of hazard zone for host machine.
	During installation check it may be required to be temporarily in the hazard zone. Use approved PPE. Take extreme care against flying objects.

Keep yourself and bystanders out of the hazard zone. Stop operation immediately if bystanders enter the hazard zone.

There are several different hazard zone levels for this equipment. The risks for bystanders in hazard zone I are related to crushing by hammer, carrier, boom or other heavy equipment. This hazard zone is within 5 meters (15 ft) of the machinery.

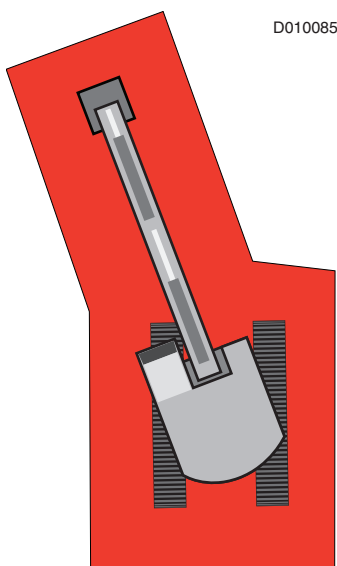

Nobody is allowed in hazard zone I during hammer operation.

**WARNING!**

It is the user's obligation to stop the hammer operation immediately if bystanders come into hazard zone I.

The risks to bystanders in hazard zone II are related to noise, dust, flying fragments of rock, pressurized oil from hydraulic hose failure or others. This hazard zone is 40 m (130 ft) from the hammer for each single one of these hazards.

It is the user's obligation to stop hammer operation immediately, when people come into hazard zone II.

Where required, make sure that site access is restricted by barriers or fences. This will frequently be necessary in road construction or demolition applications.

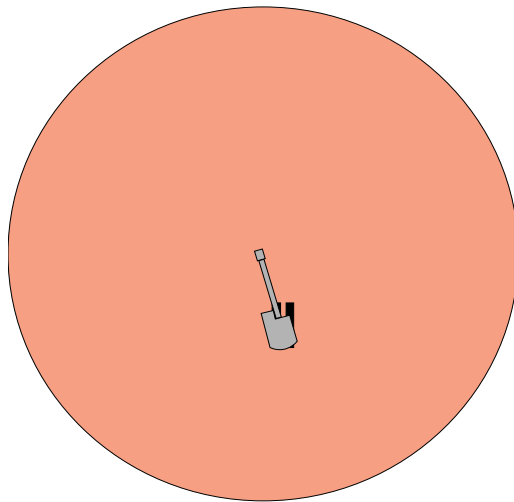

D010086

Hazard zone III is related to the stability of the carrier. It is the user's obligation to ensure that the stability of carrier is proper in all working directions, especially when the boom is sideways to the undercarriage.

3. SAFETY SECTION

This safety section explains the work related risks and gives instructions for proper protective measures against hazards, which may occur on any site.

Read and understand the protective measures listed in this safety section before using the hammer.

3.1 LIFTING

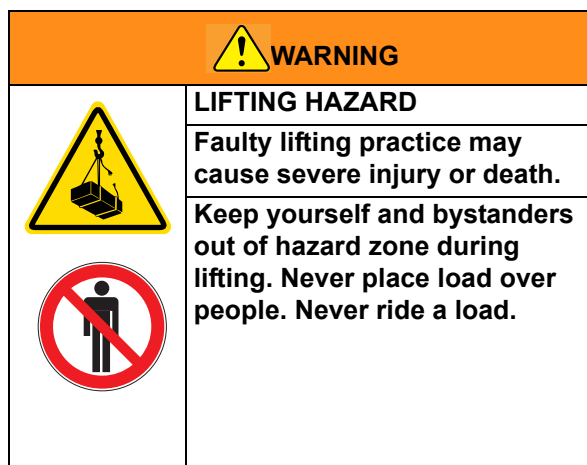

Check hammer weight from the serial label on hammer. Check weight of mounting bracket and tool as well. Especially with pin mount hammer, check the combined weight of the hammer and quick hitch mounting bracket.

Make sure that carrier, lifting and transport equipment has proper capacity to carry the weight of the product.

Faulty lifting procedures or faulty lifting equipment may cause injury or death. Use proper and approved lifting accessories for lifting of parts heavier than 20 kg (44 lb). Do not attempt to lift, turn or move heavy parts manually.

Apply lifting accessories properly and securely. Make sure that the lifting eye is properly fastened into the fixture. Where required, remove dirt from threaded lifting eye holes and lifting eye thread. Do not use self-made, repaired or damaged lifting accessories.

Make sure that the lifting eye is proper and approved for complete the product weight, especially where the mounting bracket is applied. Lifting eyes are not to be side loaded during a lifting operation. Use shim plates under the lifting eye or rotating lifting eyes to avoid unfavorable load direction on lifting eye.

Do not use the lifting eye on the impact unit for lifting of complete product.

Do not use the product or the product's tool for lifting of objects. In most cases the safe lifting capacity of the carrier is extensively utilized with the weight of product, bracket and tool.

Safety instructions for lifting

Below are some common safety instructions concerning lifting operations. In addition to this, always observe the national standards for machines and lifting-tackles strictly. Note that the list below is not all inclusive. Always ensure that the procedure you choose is safe for yourself and bystanders.

- Do not lift load over people. Allow nobody to go under the hoisted load.
- Do not lift people and never ride the hoisted load.
- Avoid side pull of the load. Make sure you take up the slack slowly. Start and stop carefully.
- Lift load a few centimeters and verify it before proceeding. Make sure the load is well balanced. Check for any loose items.
- Never leave the suspended load unattended. Maintain load control at all times.
- Never lift a load heavier than the rated capacity.
- Inspect all lifting equipment before use. Do not use twisted or damaged lifting equipment. Protect the lifting equipment from sharp corners.
- Obey all local safety instructions.

3.2 PACKING, TRANSPORTATION AND STORAGE

Stay clear of hot surfaces. Wear approved PPE.

Use proper and approved lifting accessories for lifting of parts heavier than 20 kg (44 lb). Do not attempt to lift, turn or move heavy parts manually. A sudden change of balance may result in unexpected movement of equipment.

Check hammer weight from the serial label on hammer. Check weight of the mounting bracket and tool as well. Especially with pin mount hammer, check the combined weight of the hammer and quick hitch mounting bracket.



Make sure that the carrier, the lifting- and the transport equipment have proper capacity to carry the weight of the product.

During transport, secure other parts, such as hoses, tools and tool box properly, so that these cannot move uncontrolled.

Secure the product properly during transportation and storage. Follow proper transportation practices. Short term storage in horizontal position only.

Store the product horizontally on level ground, which is able to support the load. Store and transport the product on pallet with proper load capacity. Do not stack products or pallets with products on top of each other.

3.3 PRESSURIZED GAS IN ACCUMULATOR

 DANGER	
 	HIGH PRESSURE HAZARD
	Faulty handling of pressurized accumulator will cause death or severe injury.
	READ WORKSHOP MANUAL before disassembly!
	Recharge with NITROGEN (N ₂) only!

Before for example an air freight, as well as before any workshop service of the hammer, depressurize the accumulator.

Use only nitrogen (N₂) for recharging the accumulators. The use of other gas may cause accumulators to explode. Failure to comply can result in serious injury or death.

The accumulator charging device does not have any pressure relief valve. Shut gas the bottle valve when the gauge shows the correct charging pressure.

Do not disassemble the hammer before releasing gas pressure from the accumulators and oil pressure from the hammer. Failure to comply could result in serious injury or death.

3.4 CRUSHING PREVENTION AND CUTTING PREVENTION

 WARNING	
	CRUSHING HAZARD Moving or falling equipment, objects or parts may cause severe injury or death!
	Keep yourself and bystanders out of hazard zone.
	

Never mount or dismount the hammer to or from the carrier with the hammer in vertical position and supported by tool in ground only. The 'breaking' action of the tool will make even relatively hard ground extremely unstable.

Make sure that the carrier is able to properly support the load of the product in all directions and in all working situations. Stability is an issue especially in long reach applications.

Support the product properly when you perform work beneath the product. Do not depend on the hydraulic cylinders in order to support the product. A product can fall if a control lever is moved or if a hydraulic line breaks. Also, a product can fall if a hydraulic cylinder drifts.

Whenever there are hammer control linkages, the clearance in the linkage area changes with movement of the hammer.

Stay clear of all rotating parts and all moving parts. Unless you are instructed otherwise, never attempt adjustments while the machine is moving or while the engine is running.

During storage and transportation make sure that the load is secured in a proper way. Use proper pallets and make sure the ground is able to support the load.

3.5 REMOVAL FROM PACKAGE AND INSTALLATION

Clean ice, snow, water, oil or grease spills from the floor to prevent slipping, tripping or falling. Use approved safety boots. Dispose properly (recycle) of spill oil and grease. Make sure that lighting conditions are good enough to allow for safe working.

Use proper and approved lifting accessories for lifting of parts heavier than 20 kg (44 lb). Do not attempt to lift, turn or move heavy parts manually. A sudden change of balance may result in unexpected movement of equipment.

Visually check that all parts and bolts of the hammer are in place. Check the hammer weight from the serial label on hammer. Check weight of the mounting bracket and tool as well.

Sudden movement of parts, which were stuck, but become loose may cause crushing of body parts. Beware of sharp edges of parts. Beware of noise from pneumatic or other tools. Wear approved PPE.

Make sure that the carrier, lifting and transport equipment has proper capacity to carry the weight of the product.

Secure the product properly during transportation. Follow proper transportation practice. Secure the product properly during installation. Always keep the product in horizontal position, while mounting to carrier!

Agree with your colleagues on site on the use of hand signals. Do not assume any knowledge of signals.

Place the carrier on stable, level ground before starting any installation, service or maintenance on equipment. Do not climb on the product. There is always hazard zone around the product. Use proper working platform for safe access. Where working platforms are used, make sure to place them on level and stable ground.

During installation check it may be required to be temporarily in the hazard zone of the product. Use approved PPE. Take extreme care against flying objects.

Flying fragments are an extreme hazard, while driving in the tool retaining pin or other pins. Use approved eye protection. Use proper tools. Use approved PPE.

Check the tool retaining pins on a regular basis. Check the tightness of the bracket bolts on a regular basis.

Place the boom in a proper position to allow for ergonomic way of connecting hoses. Check hose ends for proper connection on a regular basis. Use only suitable bolts with proper capacity for mounting of product

Always check the hammer function and installation outdoors. Stop the engine, when use is not required. Make sure that proper ventilation of exhaust gases is available, when the engine is running.

Check the mounting pin locking mechanism on the carrier for the pin mounted hammer or mounting bracket for a bracket mounted hammer on a regular basis.

3.6 BEFORE USE AND NEW USERS

Secure the product properly during transportation. Follow proper transportation practice. Make sure that carrier, lifting and transport equipment has proper capacity to carry the weight of the product.

Place the carrier on stable, level ground before starting any installation, service or maintenance on the product. Do not climb on the product. There is always a hazard zone around the product. Use a proper working platform for safe access. Where working platforms are used, make sure to place this on level and stable ground.

Keep yourself and bystanders out of the hazard zone of the carrier.

Beware of heavy vibration! Do not touch a vibrating hammer or pulsating hoses. Vibration makes it extremely difficult to take off hands. Use a plastic spiral over hoses to protect against pinhole leaks. Use cardboard to check on a pinhole leak. Wear proper PPE.

Visually check that all parts and bolts of the product are in place. Check the tool retaining pins on a regular basis. Check the tightness of the bracket bolts on a regular basis.

Flying fragments are an extreme hazard, while driving in the tool retaining pin or other pins. Use approved eye protection. Use proper tools. Use approved PPE.

Place the boom in proper position to allow for an ergonomic way of connecting the hoses. Check the hose ends for proper connection on a regular basis. Use only suitable bolts with proper capacity for the mounting of the product.

Always check the hammer function and installation outdoors. Stop the engine, when use is not required. Make sure that proper ventilation of exhaust gases is available, when the engine is running.

Check the mounting pin locking mechanism on the carrier for a pin mounted hammer or the mounting bracket for a bracket mounted hammer on a regular basis.

Clear all obstacles that are in the path of the machine. Beware of hazards such as wires and ditches.

Check the stability of the level where you are working. Falling down a level with carrier will cause severe injury or death.

Know the width of your equipment in order to maintain proper clearance when you operate the equipment near fences or near boundary obstacles.

Be aware of high voltage power lines and power cables that are buried. If the machine comes in contact with these hazards, serious injury or death may occur from electrocution.

Be aware of water and sewage pipelines that are buried.

3.7 OPERATION

Make sure that the lighting conditions are good enough to allow for safe working. Move carefully on site to avoid tripping, slipping or falling. Use approved safety boots.

Secure the product properly during transportation. Follow proper transportation practice. Store and transport the product on pallet with proper load capacity. Make sure that carrier, lifting and transport equipment has proper capacity to carry the weight of the product. The product or the lifting eye on the product must not be used to lift external loads.

Place the carrier on a stable, level ground before starting any installation, service or maintenance on the product. Do not climb on the product. There is always a hazard zone around the product. Use proper working platform for safe access. If you use a working platform, make sure to place this on level and stable ground.

Perform Real Time Hazard Analysis on site at least daily before starting up. Determine an escape route for emergency situations. Agree with your colleagues on site on the use of hand signals. Do not assume any knowledge of signals.

Always keep people informed of what you are doing when and where. Keep a mobile phone always at hand. Inform the site manager, when you leave the site.

Keep yourself and bystanders out of hazard zone for the carrier.

With tractor backhoe loader, do not ever drive while boom and hammer are outside wheel width sideways. Driving with the hammer in this 'transport' position may cause severe damage to pedestrians or passing cars.

Use of hammer in explosive atmosphere (gasoline fumes, coal dust...) is strictly prohibited.

Beware of heavy vibration! Do not touch a vibrating hammer or pulsating hoses. Vibration makes it extremely difficult to take off hands. Use a plastic spiral over hoses to protect against pinhole leaks. Use cardboard to check on a pinhole leak. Stay clear from hot surfaces. Wear proper PPE.

Extended exposure to whole body vibration may damage your health. Install suitable seating in cab. Rammer strongly recommends to use hammer only on carriers equipped with ROPS/FOPS.

Visually check that all parts and bolts of the product are in place. Check the tool retaining pins on a regular basis. Check the tightness of the bracket bolts on a regular basis.

Flying fragments are an extreme hazard, while driving in the tool retaining pin or other pins. Use approved eye protection. Use proper tools. Use approved PPE.

Stop the engine, when use is not required. Make sure that proper ventilation of exhaust gases is available, when engine is running.

Check the mounting pin locking mechanism on the carrier to pin mounted hammer or a mounting bracket for the bracket mounted hammer on a regular basis.

Respiratory Silica Dust will cause severe injury or death. Always wear an approved respirator.

Use vertical steel bars, a separate plastic net or a plastic window for operator cab protection. Use an air conditioned cab in high temperature applications (metallurgical or similar) as well as at high ambient temperature. In high reach or similar bad ergonomics applications, rest tense muscles at regular intervals.

This product is for professional use only. Special conditions, such as radioactive, asbestos, chemical, poisonous or biological hazard environment require unconditional use of hazard specific methods and protective measures.

3.8 TRAPPED PRESSURE IN HYDRAULIC SYSTEM

Unreleased trapped pressure can cause sudden machine movement or attachment movement. Use caution if you disconnect hydraulic lines or fittings. High pressure oil that is released can cause a hose to whip. High pressure oil that is released can cause oil to spray. Oil may be hot after prolonged operation.

If you use a lubrication system, make sure to relieve all pressure before any lines, fittings or related items are disconnected.

Before disconnecting or connecting hydraulic hoses, stop the carrier engine and operate controls to release pressure trapped in the hoses.

Pressure can be trapped in the hydraulic circuit long after the engine has been stopped. The pressure can cause hydraulic fluid or items such as pipe plugs to escape rapidly if the pressure is not relieved correctly.

Wait at least 10 minutes to ensure that the pressure has been relieved from the system before disconnecting any hoses, pipes or other components. Failure to comply could result in a serious injury or death.

3.9 HOT SUBSTANCES

Hot oil and hot components can cause personal injury. Do not allow hot oil to contact the skin. Also, do not allow hot components to contact the skin.

Relieve all pressure in the air system, in the hydraulic system, or in the lubrication system before any lines, fittings or related items are disconnected.

Metal parts, such as valves or body parts may have the same temperature as the hydraulic oil.

The working end of the tool may get extremely hot during operation. Make sure the tool has had time to cool down before starting to handle it.

3.10 CONTAINING FLUID SPILLAGE

Ensure that fluids are contained during performance of inspection, maintenance, testing, adjusting and repair of the equipment. Prepare to collect the fluid with suitable containers before opening any compartment or disassembling any component containing fluids.

Use tools and equipment that are suitable for containing and collecting fluids.

Improperly disposing of waste can threaten the environment. Always use leakproof containers when you drain fluids. Do not pour waste onto the ground, down a drain, or into any source of water.

Obey all local regulations for the disposal of liquids.

3.11 CLEANING AND SERVICE

Replace all damaged, lost or otherwise illegible safety labels.

Clean ice, snow, water, oil or grease spills from the floor to prevent slipping, tripping or falling. Use approved safety boots. Dispose properly (recycle) of spill oil and grease.

Do not climb on the product. There is always a hazard zone around the product. Use proper working platform for safe access.

Beware of heavy vibration! Do not touch a vibrating hammer or pulsating hoses. Vibration makes it extremely difficult to take off hands. Use a plastic spiral over hoses to protect against pinhole leaks. Use cardboard to check on a pinhole leak. Stay clear from hot surfaces. Wear proper PPE.

Wait for hydraulic oil inside the hammer to cool down, before disassembly or service. Oil inside the hammer may be extremely hot. Do not handle hydraulic hoses (connect/disconnect) while oil is hot. Use approved PPE.

Flying fragments are an extreme hazard, while driving in the tool retaining pin or other pins. Use approved eye protection. Use proper tools. Use approved PPE.

Plug pressure and return line before washing the product, to prevent water and dirt from entering into the product.

Pressurized air and/or water can cause debris and/or hot water to be blown out. This can result in personal injury.

When pressurized air and/or pressure water is used for cleaning, wear protective clothing, protective shoes, and eye protection. Eye protection includes safety glasses or a protective face shield.

The maximum air pressure for cleaning purposes must be below 205 kPa (30 psi). The maximum water pressure for cleaning purposes must be below 275 kPa (40 psi).

3.12 FIELD REPAIR

Place carrier on stable, level ground before starting any installation, service or maintenance on the product. Release internal pressure from hammer and accumulator before service, disassembly or scrapping. **Charge accumulator with nitrogen only!** Use approved PPE.

Do not attempt to lift, turn or move heavy parts manually. A sudden change of balance may result in unexpected movement of equipment.

While changing the tool, make sure not to leave fingers, hands or other body parts between the tool and the ground or the product. Stay clear from hot surfaces. Wear approved PPE.

Secure the product properly during field service. Always keep the product in horizontal position! Beware of unexpected boom movement. Do not climb on the product. There is always a hazard zone around the product. Use proper working platform for safe access.

Flying fragments are extreme hazard, while driving in tool retaining or other pins. Use approved eye protection. Use proper tools. Use approved PPE.

Attach a "Do Not Operate" warning tag or a similar warning tag to the start switch or to the controls before you service the equipment or before you repair the equipment.

Unless you are instructed otherwise, never attempt adjustments while the machine is moving or while the engine is running. Stay clear of all rotating parts and all moving parts.

Before welding on the hammer while it is mounted on the carrier, disconnect the carrier alternator and battery. Note that welding on hammer tools will render them useless.

Use all cleaning solutions with care. Never put maintenance fluids into glass containers. Drain all liquids into a suitable container.

3.13 DISMOUNTING

Make sure that carrier, lifting and transport equipment have proper capacity to carry the weight of the product.

Keep yourself and bystanders out of hazard zone during lifting. Never place load over people. Never ride a load. Do not use self-made, repaired or damaged lifting accessories. Apply lifting accessories properly and securely. Secure the product properly during transportation. Follow proper transportation practice.

While changing the tool, make sure not to leave fingers, hands or other body parts between the tool and the ground or the product.

Oil inside the hammer may be extremely hot. Do not handle hydraulic hoses (connect/disconnect) while oil is hot. Stay clear from hot surfaces. Use approved PPE.

Secure the product properly during field service. Always keep the product in horizontal position! Beware of unexpected boom movement. Do not climb on the product. There is always a hazard zone around the product. Use proper working platform for safe access.

3.14 WORKSHOP SERVICE

Workshop service must be performed at a trained and Rammer approved workshop. Non-professional service is a severe risk for the staff performing the service. Non-professional service is a safety risk for the operator as well, with a high risk of material damage, which may become extremely expensive.

3.15 SCRAPPING

While removing the tool, make sure not to leave fingers, hands or other body parts between the tool and the ground or the product.

Release the internal pressure from the hammer and the accumulator before service, disassembly or scrapping. Drain the hydraulic hammer of fluids before scrapping. Use approved PPE.

Plastic (wear plates, foam rubber...) and rubber (seals, vibration dampening elements, plugs) parts should be deposited at dump. Do not burn.

Obey all local regulations in the disposal of liquids.

Improperly disposal of waste can threaten the environment. Always use leakproof containers when you drain fluids. Do not pour waste onto the ground, down a drain, or into any source of water.

Recycle all metal parts of the product as standard scrap recycling.

3.16 FLAMMABLE LIQUIDS

All fuels, most lubricants, and some coolant mixtures are flammable.

Flammable fluids that, are leaking or spilled onto hot surfaces or onto electrical components can cause a fire. Fire may cause personal injury and property damage.

Remove all flammable materials such as fuel, oil, and debris from the hammer. Do not allow any flammable materials to accumulate on the hammer.

Store fuels and lubricants in properly marked containers away from unauthorized persons. Store oily rags and any flammable materials in protective containers. Do not smoke in areas that are used for storing flammable materials.

Do not operate the product near any flame.

Do not weld on lines or on tanks that contain flammable fluids. Do not flame cut lines or tanks that contain flammable fluid. Clean any such lines or tanks thoroughly with a non-flammable solvent prior to welding or flame cutting.

4. SAFETY DURING OPERATION

4.1 PROPER OPERATING PRACTICE

Only operate the hammer while you are in the seat of the carrier. The seat belt must be fastened while you operate the carrier. Only operate the controls while the engine is running. Wear protective glasses while you operate the carrier and while you operate the hammer.

While you operate the hammer slowly in an open area, check for proper operation of all controls and all protective devices. Before you move the carrier, ensure that no one will be endangered.

Carry the hammer low to the ground. Do not go close to the edge of a cliff, an excavation, or an overhang.

Maintain control of the carrier while you operate the hammer. Operating the equipment beyond its design limits can cause damage to people or equipment.

Know the maximum operating dimensions of your carrier when the hammer is installed.



Ensure that there is adequate clearance between the tool and any stationary objects when you are maneuvering the machine.

Know the appropriate work site hand signals and the personnel that are authorized to give the hand signals. Confirm your understanding of the signs with the other personnel before starting. Accept hand signals from one person only.

Do not allow unauthorized personnel on the equipment.

During operation, the tip of the tool may get extremely hot. Do not operate the hammer near flammable liquids.

4.2 AIRBORNE POLLUTION

 DANGER	
 	DUST HAZARD
	Breathing dust will cause death or severe injury!
	Always wear approved respirator!

Protect yourself and bystanders from airborne pollution. Breathing or inhaling dust particles will cause death or severe injury.

Always work with a respirator approved by the respirator manufacturer for the job you are doing. It is essential that the respirator that you use protects you from the tiny dust particles which cause silicosis and which may cause other serious lung diseases.

Do not use the equipment until you are sure your respirator is working properly. This means you must check the respirator to make sure that it is clean, that its filter has been changed, and to otherwise make sure the respirator will protect you in the way it is meant to.

Make sure the dust suppression system in your equipment is working properly. If the dust suppression system is not working properly, stop working immediately.

Always make sure dust has been cleaned off your boots and clothes when you leave your shift.

The smallest particles of dust are the most harmful. They may be so fine that you can not see them.

Remember, you must protect yourself from the danger of breathing or inhaling dust. Failure to comply will result in serious injury or death.

The related safety label on the product and the text on the label are shown below.

"DUST HAZARD

Breathing dust will cause death or severe injury.

Always wear approved respirator."



4.3 FLYING FRAGMENTS IN OPERATION

Protect bystanders against flying chips of rock. Do not operate the hammer or the carrier if people without proper PPE are near the equipment.

The safe distance for unprotected people is approx. 40 m (130 ft). The hammer must be stopped immediately, when the operator observes people without proper PPE to come any closer than this.

Where there is need to work at closer distance to unprotected people or structures, erect safety barriers that can stop flying fragments.

Also erect safety barriers if unprotected bystanders may be crossing through the hazard zone (= reasonably foreseeable misuse).

Protect yourself against flying chips of rock. Flying objects or debris can cause serious injury or death. To prevent injury to your eyes or to your ears, wear eye protection and hearing protection when you operate the machine.

The European standard EN 474-1 on safety of earth-moving machinery requires that adequate operator's protection, such as bullet proof glass, mesh guard or an equivalent protection is used on carriers equipped with a hammer.

Always make sure the machine is equipped with a flying object guard.

When measuring hammer operating pressure, you are working in the hammer's hazard zone. Stay clear of moving equipment. Use proper PPE. Failure to comply could result in serious injury or death.

"FLYING OBJECTS HAZARD

The safety label on the product is shown below:

Fragments fly up to 40 m (130 ft) and could cause death or severe injury.

Stop operation when a person enters hazard zone.

Wear approved personal protective equipment."

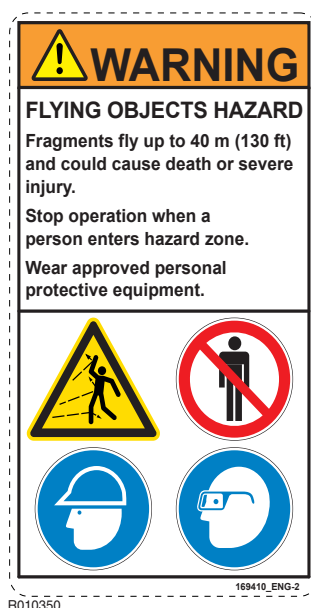

4.4 NOISE

A product in operation creates a high noise level. Always wear ear protection to prevent personal injury.

The safety label on the product is shown below:

"NOISE HAZARD

Continuous exposure to noise above 80 dB(A) will cause hearing impairment.

Wear approved hearing protectors."

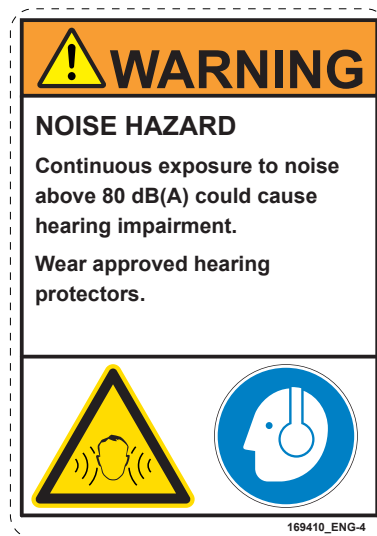

169410_ENG-4

R010351

4.5 HIGH PRESSURE PINHOLE LEAKAGE

Fine jets of hydraulic fluid at high pressure can penetrate the skin, causing serious allergic reaction and gangrene.

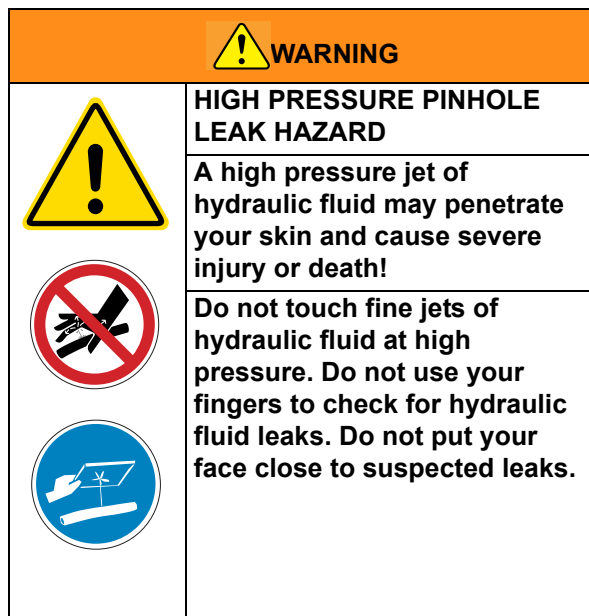

Always hold a piece of cardboard close to suspected leaks and then inspect the cardboard for signs of hydraulic fluid leak. If fluid is injected into your skin, you must get treatment immediately. Seek treatment from a doctor, who is familiar with this type of injury.

During hammer operation, keep people away from the hydraulic hoses.

Hydraulic fluid at system pressure may cause injury. Before disconnecting or connecting hydraulic hoses, stop the carrier engine and operate the controls to release pressure trapped in the hoses.

Make sure to let the hydraulic fluid cool down to ambient temperature, before disconnecting the hoses.

Always use leakproof containers when you drain fluids. Do not pour waste onto the ground, down a drain, or into any source of water.

Improper disposal of waste can threaten the environment. Potentially harmful fluids should be disposed of according to local regulations.

4.6 ASBESTOS, RADIOACTIVE OR POISONOUS APPLICATIONS

Protect yourself and bystanders from asbestos, radioactive or poisonous airborne pollution.



Stop immediately working on the site, when you suspect that asbestos, radioactive or poisonous material is on the site unexpectedly. Advise the site supervisor and authorities on your findings.

If you are aware of asbestos, radioactive or poisonous material on site, follow all local laws and regulations for this application. Use gas masks and other proper personal protective equipment.

Use proper personal protective equipment, including pressurized suits. It is essential that you protect yourself and people in your surrounding from the tiny dust particles which cause asbestosis and other serious lung diseases. Do not use the product until you are sure the respirators are working properly. This means you must check the respirator to make sure that it is clean, that its filter has been changed, and to otherwise make sure the respirator will protect in the way it is meant to.

Rammer equipment and replacement parts that are shipped from Rammer are asbestos free. Rammer recommends the use of only genuine Rammer replacement parts. Use the following guidelines when you handle any replacement parts that contain asbestos or when you handle asbestos debris.

Equipment components which may contain asbestos fibers are brake pads, brake bands, lining material, clutch plates, and some gaskets. The asbestos that is used in these components is usually bound in a resin or sealed in some way. Normal handling is not hazardous.

If dust that may contain asbestos is present, follow the basic guidelines below:

- Never use compressed air for cleaning.
- Avoid brushing materials that contain asbestos.
- Avoid grinding materials that contain asbestos.
- Use a wet method in order to clean up asbestos materials.
- Use exhaust ventilation on permanent machining jobs.
- Wear an approved respirator if there is no other way to control the dust.
- Comply with applicable rules and regulations for the work place. In the United States, use Occupational Safety and Health Administration (OSHA) requirements.
- Obey environmental regulations for the disposal of asbestos.
- Stay away from areas that might have asbestos particles in the air.
- Dispose of waste properly.

Failure to comply will result in serious injury or death.

5. TRANSPORTATION, STORAGE AND SETTING UP

5.1 TRANSPORT POSITION

The transportation and parking positions are shown in the illustration. When moving with the hammer, ensure that it is not too close and does not point at the cabin window.

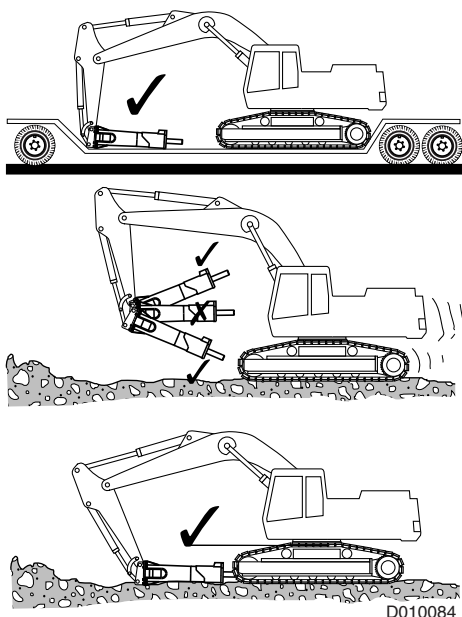

When moving the hammer without the mounting bracket, install a plate or a beam to the housing to prevent the hammer from falling out of the housing.

Refer to the Operation and Maintenance Manual of the carrier for additional information on transporting the carrier.

5.2 STORAGE

Observe the following points when the hammer is stored. In this way the vital parts of the attachment are protected from rust and the machine is ready to be installed whenever necessary.

- Make sure the storage area is dry.
- Remove the tool from the hydraulic hammer.
- Protect the lower end of the piston, the tool and the tool bushings well with grease everywhere within the hydraulic hammer.
- Seal the connections with clean plugs to prevent oil leakage and dirt from getting into couplings.
- Store the product in the vertical position.
- Make sure the product cannot fall.

5.3 SETTING UP

Verify that the hammer is compatible with the carrier. Consult your Rammer dealer for more information.

Verify that all parts you have specified are delivered.

Verify that the mounting bracket (standard or quick hitch) is the correct mounting bracket for the carrier and the product.

Verify that the oil hoses are specified for maximum pressure relief setting.

If the carrier is equipped with a quick hitch mounting bracket, consult the operating manual of the quick hitch bracket before you attempt to mount the product.

- An excessively heavy bracket may increase the weight of the attachment more than the lifting capacity of the carrier allows.
- A too light bracket may not be able to support the product properly.
- Faulty bracket geometry may lead to contact and cause expensive damage to the boom cylinders.

Mount or dismount the hammer to or from the boom only while the hammer is in a horizontal position. If the hammer is in a standing position, it may fall over due to insufficient support from ground or due to sudden movement of the boom.

Tighten the bracket bolts to the proper torque value.

When measuring hammer operating pressure, you are in the hammer's hazard zone. Stay clear of moving equipment. Use proper PPE. Failure to comply could result in serious injury or death.

After maintenance or a long period of storage, fill the hammer with oil. Lift the hammer off the ground, press the hammer's operating switch, and drive oil through the hammer for a couple of minutes.

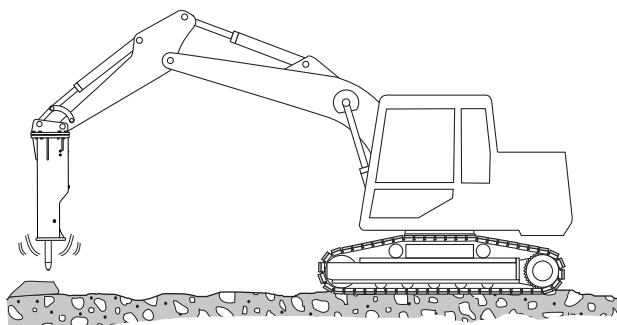

BA010031

6. HAMMER INSTALLATION AND REMOVAL

6.1 PREPARING FOR INSTALLATION

Before you install the hammer, verify the setup of the hydraulic system for the carrier. Perform the following steps:

- Verify the setting of the relief valve for the auxiliary system. If the pressure is not correct, adjust the relief valve to the proper pressure setting.
- Verify the back pressure of the return flow of the hydraulic system. Refer to the "Specifications" section for the proper specifications for your machine. See "Hammer specifications" on page 94. For more information, consult your Rammer dealer.

Before operation, replace the lifting eye with a bolt. If the lifting eye is left in place, heavy vibration, will create cracks in the housing.

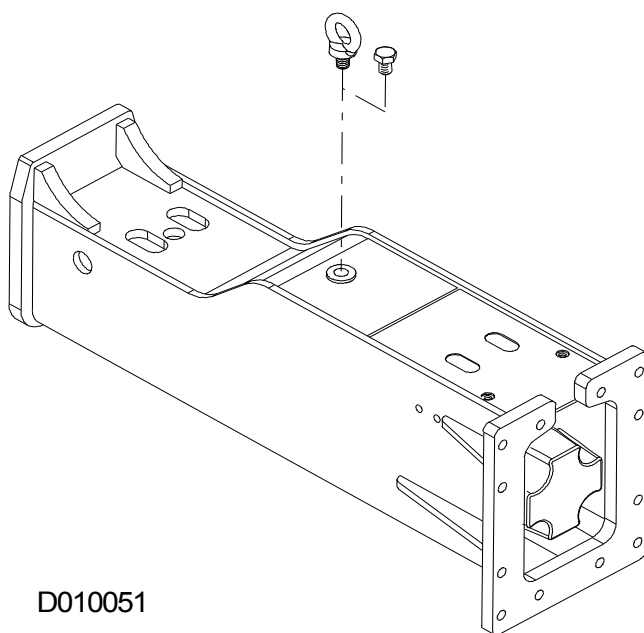

D010051

6.2 INSTALLING THE HAMMER

**WARNING!**

Never install the hammer to the carrier or remove it from the carrier by yourself. These tasks require more than one person.

**WARNING!**

Secure the hammer from falling down in any direction when handling it. Check that the lifting capacity of the hoist you are using is sufficient for the job.

1. Move the carrier to the hammer, taking care not to hit any bystanders.
2. Lower the boom carefully towards the hammer.

Do not place yourself or other people under the hammer or the boom at any time. Sudden, unexpected movements of the boom may crush your limbs.

3. Mount the hammer on the boom. Take care not to get hit by pins or links.
4. Tighten the bracket bolts to the proper torque value.
5. Remove protective caps. Connect the hoses. Make sure you collect all oil in a proper container and dispose of it properly.

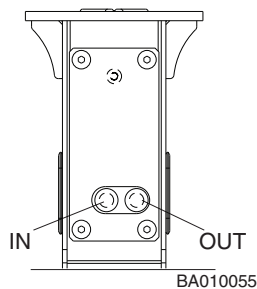

6. Open the pressure line and tank line valves on the boom.
7. Check that oil flow, operating pressure and return line pressure are within specifications. See “Hammer specifications” on page 94.

6.3 REMOVING THE HAMMER

**WARNING!**

Never install the hammer to the carrier or remove it from the carrier by yourself. These tasks require more than one person.

**WARNING!**

Secure the hammer from falling down in any direction when handling it. Check that the lifting capacity of the hoist you are using is sufficient for the job.

1. Move the carrier and the hammer to solid, clean ground.
2. Lower the boom and the hammer to the ground, placing the hammer on solid and level wooden blocks.

Do not place yourself or other people under the hammer or the boom at any instance. Sudden, unexpected movements of boom may crush your limbs.

3. Stop the engine. Turn off the main switch. Move the controls to release trapped pressure.
4. Close the pressure line and tank line valves on the boom to prevent oil from leaking to the ground.
5. Disconnect the hoses. Do not let oil inside the hammer housing. Make sure to collect all the oil in a proper container and to dispose of it properly.

Plug the hoses and pipeline ends immediately, in order to prevent dust from entering the system.

6. Remove the mounting bracket or mounting pins. Take care not to get hit by released pins or links.
7. When you store the hammer for more than a week, clean it and cover it with protective plastic.

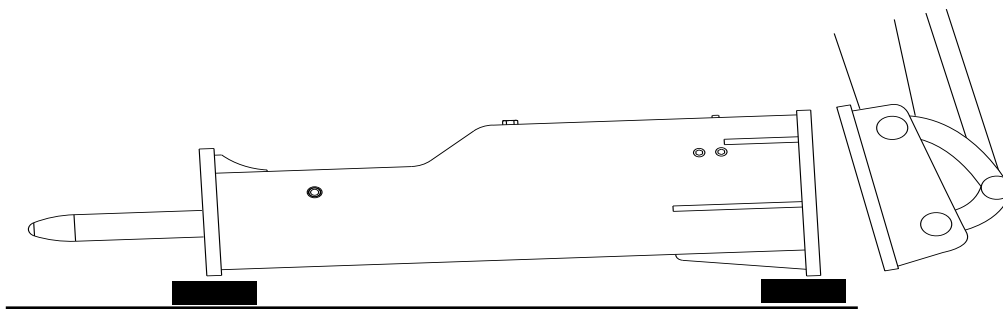

D010045

7. OPERATION

7.1 UNDERWATER USE

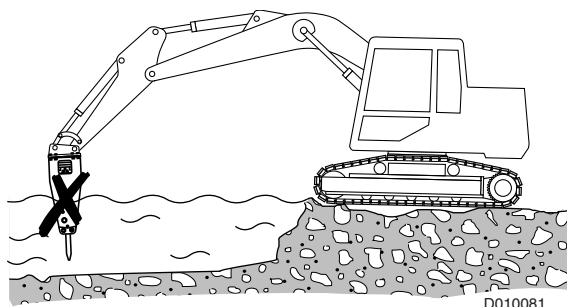

Do not use the hammer under water

If the seals get damaged in underwater use, oil may escape into the environment, such as rivers, lakes or groundwater reservoirs. Only a minor amount of hydraulic oil can completely spoil drinking water for a very long time! Water will also enter the hydraulic circuit of the carrier, resulting in expensive damage to equipment.

In addition, during underwater use strong pressure waves may damage the hammer if the space between piston and tool fills with water.

7.2 RD3 REMOTE MONITORING DEVICE

RD3 is a hammer-mounted device that enables remote monitoring of hammer units. During hammer operation, RD3 collects and transmits operating and location information. This information is available through an online service and can be used, for example, to view hammer work history, manage service schedules, optimize hammer performance, plan operator training and conduct fleet management.

For more information, contact your local Rammer dealer.

Note: See “RD3 and data privacy” on page 100.

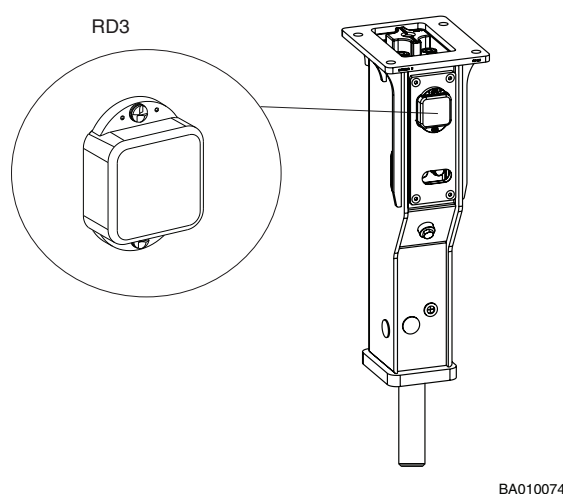

WARNING!

Warning! RD3 contains a SIM card to enable remote connections and an encased lithium metal battery. Both items are regulated for air transport. Consult your forwarder about any restrictions for air freight.



WARNING!

Warning! Lithium is a highly flammable substance. Store damaged lithium batteries in a fire proof container. Never transport a damaged or unprotected lithium battery. Follow local laws and regulations on proper disposal of damaged lithium batteries.



WARNING!

Warning! Inhalation, skin contact and eye contact can occur when the battery is opened. Upon exposure to internal contents, the corrosive fumes will be very irritating to the skin, eyes and mucous membranes. Overexposure can cause symptoms of non-fibrotic lung injury and membrane irritation.

7.3 IDLE STROKES

Idle strokes occur when the hammer piston is operated without material or an object under the tool.

Constant idle strokes have a deteriorating effect on the hammer and the side plates, causing them to wear out quicker. Vibrations caused by constant idle strokes damage the carrier structures and cause additional fatigue to the operator.

7.4 BLANK FIRING

Stop the hammer the moment the subject material is broken. Operating the hammer piston without material under the tool is called blank firing.

Excessive prying of the tool may prevent contact between the piston and the tool and also cause blank firing. A sign of this is when hammer recoil sound becomes extremely rapid during operation.

Blank firing will destroy major components of the hammer, starting from the tool and the tool retaining pin. Continuous blank firing will destroy the front head, the piston and the tie rods.

Rammer considers this a faulty operation technique that is not covered by warranty.

7.5 PENETRATIVE BREAKING

In penetrative breaking, a moil tool or a chisel tool is forced inside the material. Penetrative breaking is more effective in the following materials: soft material, layered material, plastic material, and low abrasive material. Hammers with a higher rate of impact (BPM) are ideal for penetrative breaking.

7.6 IMPACT BREAKING

With impact breaking, the material is broken by transferring very strong mechanical stress waves from the tool into the material. Impact breaking is most effective in hard, brittle and very abrasive materials. The high impact energy of the big hammers makes them ideal for impact breaking. The use of a chisel tool in hard material will cause the sharp edge to wear very quickly.

7.7 OPERATING TECHNIQUES

Only use the hydraulic hammer to break rocks, concrete, and other hard objects. Before you start the hydraulic hammer, place the carrier on a level, stable surface. If the carrier must be placed on a slope or on a rough surface, be careful during the operation.

Never operate the hydraulic hammer when you cannot see the hydraulic hammer. Always position the carrier so that you can see the hydraulic hammer and the area of work.

NOTICE: Do not use the dropping force of the hydraulic hammer to break rocks or other hard objects. This will cause high vibration level to operator and cause structural damage to the hammer and carrier. Rammer considers this a faulty operation technique that is not covered by warranty.

NOTICE: Do not use the sides or back of the hydraulic hammer to move rocks or other hard objects. Doing this can cause damage not only to the hammer but also to the stick or boom cylinder.

NOTICE: Do not operate the hammer with any of the cylinders fully retracted or extended. Doing this can cause structural damage to the carrier, resulting in reduced machine life.

General guidelines

- Only use the hydraulic hammer to break rocks, concrete, and other hard objects.
- Keep the hammer tool perpendicular to the surface at all times. Keep the feed force and the hammer tool aligned. If the object moves or the object's surface breaks, correct the working angle immediately.
- Do not operate the hammer while you move the hammer from one area to another area.
- Do not operate the hammer in one spot for more than 15 seconds at a time. If the object does not break, stop operation and change the position of the tool.

When you operate the hammer too long in one location, stone dust forms under the tool. Stone dust dampens the effect of impact on the object. Stone dust also produces heat. Stone dust can cause the point of the tool to become deformed.

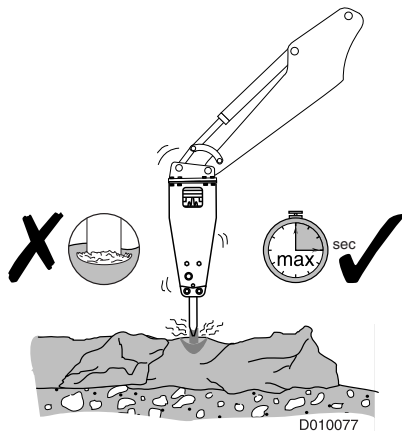

Note: Listen to the hammer's sound while you are using the hammer. If the sound is thinner and the hammer's impact is less efficient, the tool is misaligned with the object. Also, there is not enough down force on the tool. Realign the tool and press the hammer firmly against the object.

- Do not strike and pry with the tool at the same time. The tool may snap off. The tool may be bent by stones inside hard ground or frozen ground. Be careful and stop striking if you find sudden resistance under the tool.

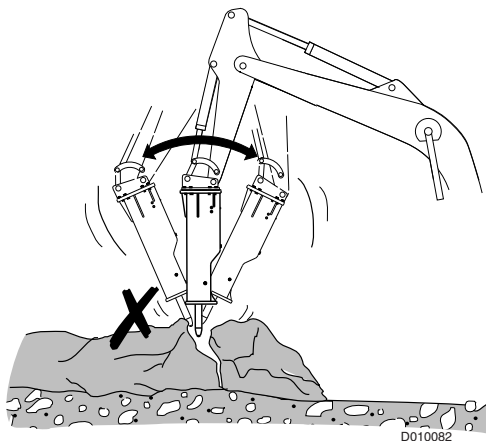

- Do not use the tool to move boulders around. The lower part of the housing is designed for moving boulders.
- Do not use a tool as a lever when it has penetrated into concrete, rock or hard ground.

The force applied will bend and or break the tool.

Rammer considers this a faulty operation technique that is not covered by warranty.

- Do not operate the hammer with the carrier's boom cylinder, stick cylinder, or bucket cylinders fully retracted or fully extended. Structural damage to the carrier will result.

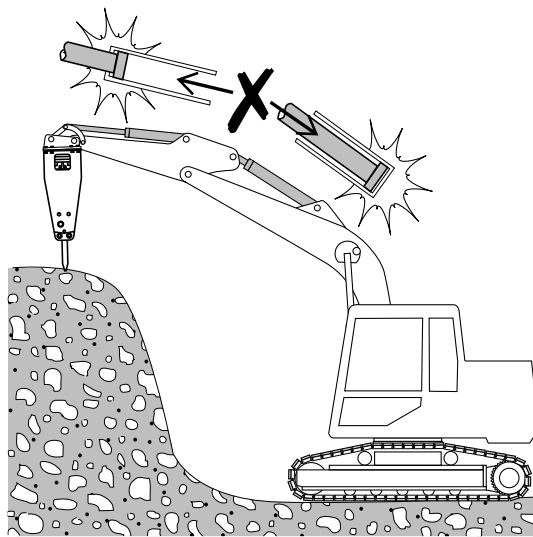

D010079

- Do not use the hammer to sweep the ground of debris. This may damage the hammer and the housing will wear out more quickly.

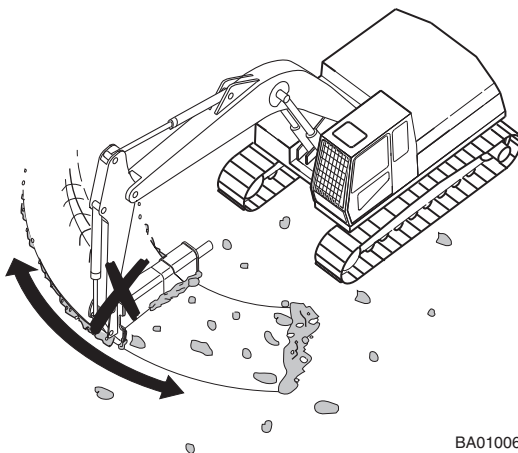

BA010060

- The hammer and the tool are not designed to be a lifting tool. The recommended carrier weight classification is limited by the carrier's ability to carry a load at the boom's end without falling over.

Do not use the hammer or the hammer tool for lifting. Failure to comply could cause severe injury or death.

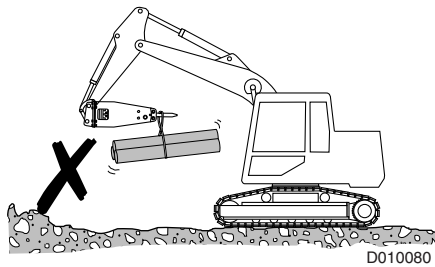
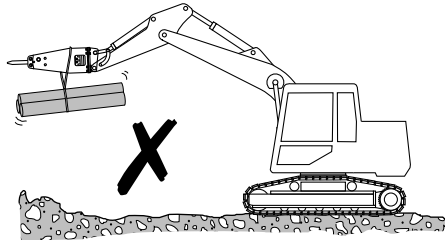

- When you operate the hammer, make sure that the hammer does not make contact with the carrier's boom or hydraulic lines.

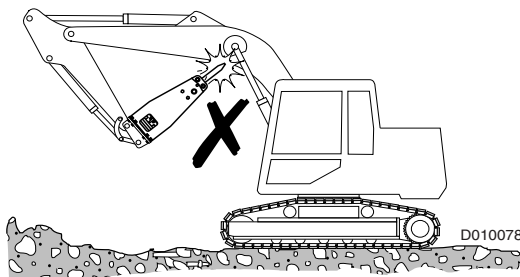

- Preheat the tool before you start to operate the hammer in temperatures that are below $-20\text{ }^{\circ}\text{C}$ ($-4\text{ }^{\circ}\text{F}$). Use a torch to preheat the tool to at least $0\text{ }^{\circ}\text{C}$ ($32\text{ }^{\circ}\text{F}$). Do not heat the tool to a temperature that is greater than $100\text{ }^{\circ}\text{C}$ ($200\text{ }^{\circ}\text{F}$).
- Keep the tool shank well greased during operation.

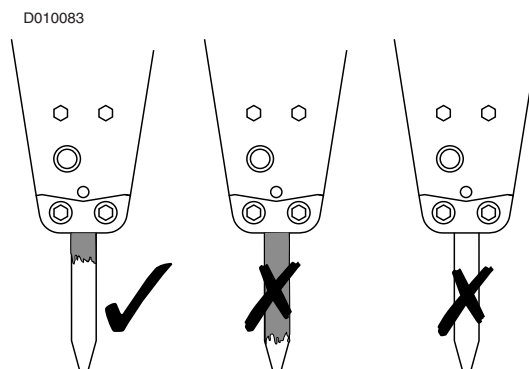

Working procedure

1. Place the carrier on a level, stable surface. If the carrier must be placed on a slope or on a rough surface, be careful during the operation.
2. Before you start the hydraulic hammer, close the front window.
3. Set the carrier's drive to neutral.
4. Set the engine speed to the recommended engine RPM.

Note: Stop the hydraulic hammer operation immediately if any of the hydraulic hoses are flexing excessively. This indicates that the accumulator is punctured. Consult your Rammer dealer for the necessary repairs.

5. Place the tool against the object at a 90° working angle. Avoid small irregularities on the object. Irregularities will break easily and cause idle strokes (blank firing). Irregularities will also cause incorrect working angles.

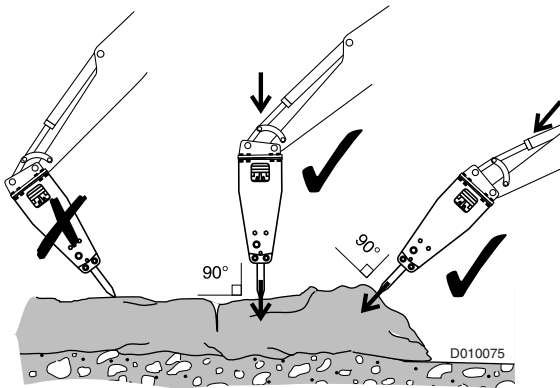

6. Use the carrier's boom to press the hammer firmly against the object. Do not pry the hammer with the boom. Correct force is applied when the carrier starts to feel light.

Too little feed will cause vibration to the boom, the carrier and the operator.

Too much feed force will cause the front of the tracks to rise in the air. When the material breaks suddenly, the carrier will fall down causing excessive vibrations to the operator and the carrier.

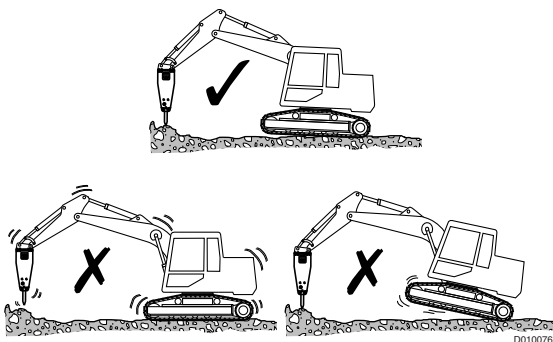

7. Start the hammer.

8. When the hammer tool penetrates the object, do not allow the hammer tool to move outward from the hammer. Keep boom down pressure on the hammer.
9. Stop operation the moment the object is broken. Do not allow the hammer to fall into the object and make idle strokes (blank firing) when the object breaks.

NOTICE: Frequent idle strokes (blank firing) have a deteriorating effect on the hammer. Do not operate the hammer without proper down pressure against the object.

NOTICE: Also excessive prying of the tool may prevent contact between the piston and the tool and cause blank firing. A sign of this is when the hammer recoil sound becomes extremely rapid during operation.

NOTICE: Blank firing will destroy major components of the hammer, starting from tool and tool retaining pin. Rammer considers this a faulty operation technique that is not covered by warranty.

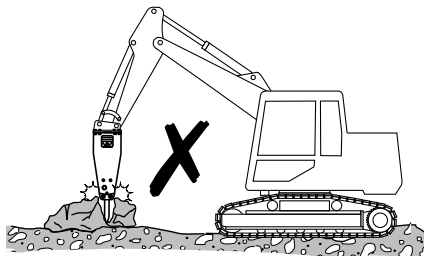
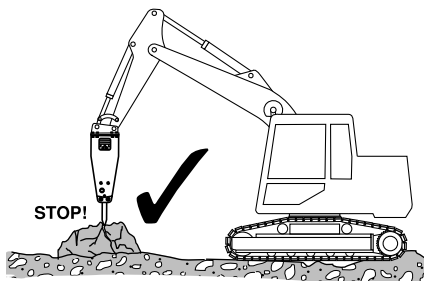

D010096

7.8 NOISE

The operation of a hammer near areas that are sensitive to noise can cause noise pollution. Follow these basic rules to avoid unnecessary noise:

- Keep the tool at 90° to the material.
- Keep the force of the feed in line with the tool.
- Replace the parts or fix the parts that are worn out, damaged, or loosened.

This will extend the life of the hammer. The noise level of the hammer will be reduced.

7.9 OPERATING TEMPERATURE RANGE

The recommended operating temperature range is -20 °C to +80 °C (-4 °F to +176 °F).

If the ambient temperature is below -20 °C (-4 °F), preheat the hammer and the tool before you start to operate the hammer. Warm up the hydraulic oil of the excavator to 30 °C ... 40 °C (80 °F ... 105 °F). This allows you to avoid breaking the membrane, and the tool. These components will remain warm during operation of the hammer.

When the hydraulic oil temperature exceeds 80 °C (176 °F), you may add an auxiliary oil cooler. When you operate the hammer at temperatures above 80 °C (176 °F), the life of the seals will be reduced.

When you operate the hammer in ambient temperatures above 30 °C (86 °F), you can use an oil with higher viscosity. The use of oil with higher viscosity can improve the life of the hammer when you operate the hammer in high ambient temperatures.

Refer to the Owner's Manual of the carrier for more information.

7.10 PROPER FEED FORCE

Push the hammer firmly down. Too little feed will cause vibration to the boom, the carrier and the operator.

Too much feed force will cause the front of the tracks to rise in the air. When the material breaks suddenly, the carrier will fall down causing excessive vibrations to the operator and the carrier.

7.11 ALIGNMENT OF THE TOOL

NOTICE: Apply feed force along the axis of the tool, and not at an angle to the material. Operating with a tilted tool will cause heavy seizure and premature failure of the tool and the piston. Rammer considers this a faulty operation technique that is not covered by warranty.

Move the hammer carefully towards the rock. Dropping the hammer will cause a high vibration to the operator and cause damage to the hammer and host machine.

7.12 OPERATION PRECAUTIONS

NOTICE: Do not operate the hammer continuously in one place. The tip of the tool will heat, get soft and wear extremely fast. Rammer considers this a faulty operation technique that is not covered by warranty.

NOTICE: Do not operate the hammer at more than fifty percent (50%) engine speed. Raising the engine speed more than necessary does not increase hammer force. With high engine speed, hydraulic oil temperature will rise and internal components will be damaged.

Always begin breaking the material at an edge, trying to remove reasonably sized pieces. This is the most efficient way to operate the hammer.

Warm up the hydraulic oil of the carrier to 30 °C ... 40 °C (80 °F ... 105 °F) before hammer operation, especially during winter time.

7.13 STOPPING OPERATION

Before leaving the carrier, always lower the boom so that the carrier is stable. Never leave the machine with the engine running.

Always engage the parking brakes before leaving the controls.

Stop operation immediately if the hoses of the hammer vibrate excessively.

Stop operation immediately if hydraulic oil is visible along the tool shaft (seal failure).

Hose vibration and seal failure call for immediate disassembly and repair of the hammer. If this happens, contact your nearest Rammer workshop.

7.14 BENDING THE TOOL

Do not use the tool to move boulders around. The lower part of the housing is designed for moving boulders.

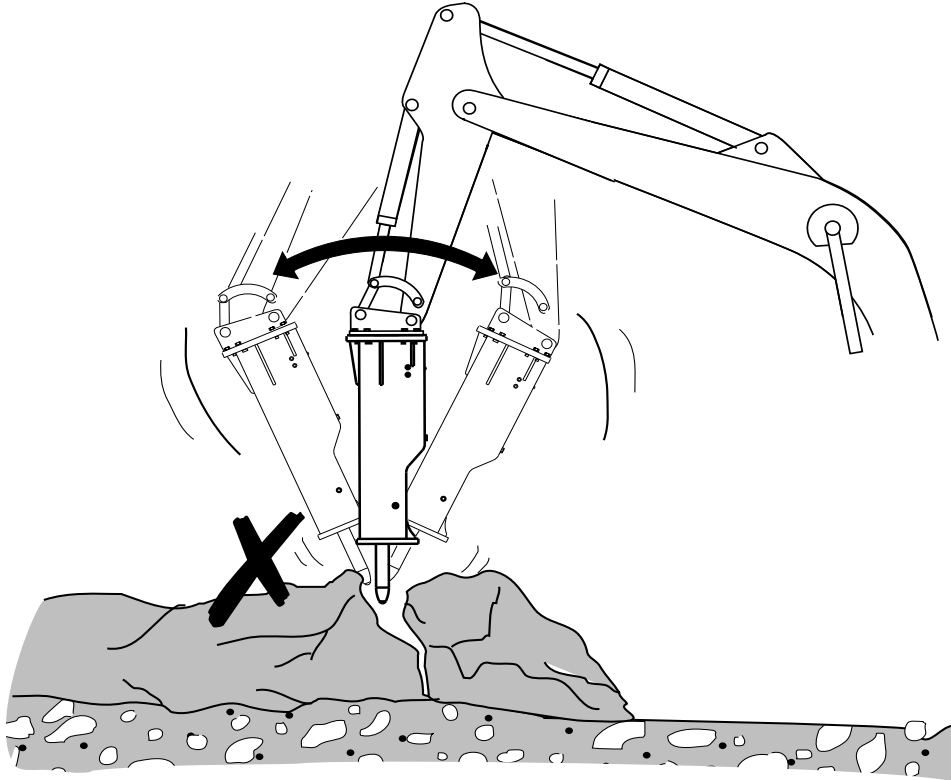

D010048

Do not use the tool as a lever, when it has penetrated into concrete, rock or hard ground. The force applied will bend and or break the tool. Rammer considers this a faulty operation technique that is not covered by warranty.

7.15 NEVER USE HAMMER OR TOOL FOR LIFTING

The hammer and the tool are not designed to be a lifting tool. The recommended carrier weight classification is limited by the carrier's ability to carry a load at end of the boom without falling over.

Never use the hammer or the tool to lift loads.

Failure to comply can cause severe injury or death.

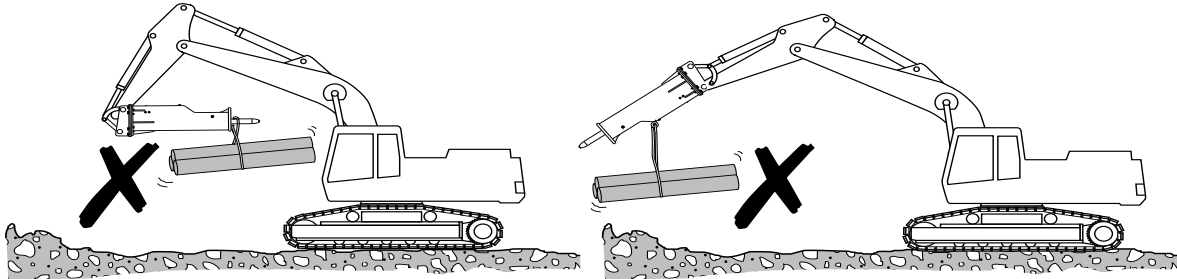

D010050

7.16 CARRIER CYLINDERS IN END POSITION

Do not operate the carrier with cylinders in either end position. Operating the hammer with the carrier's cylinders either fully extended or fully extracted will cause damage to the cylinders.

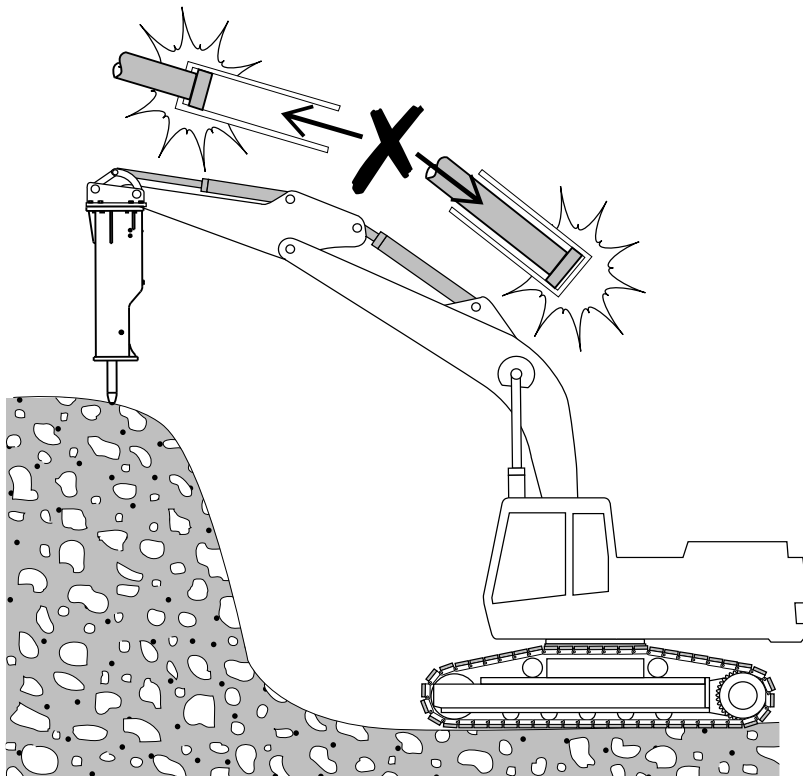

D010049

7.17 STARTING THE HAMMER AFTER MAINTENANCE OR STORAGE

After maintenance or a long period of storage, you should preheat the hammer before operation.

To preheat the hammer, follow these instructions:

1. Fill the hammer with oil.
2. Ensure that Idle Blow Protection is enabled.
3. Lift the hammer off the ground.
4. Press the hammer operating switch and drive oil through the hammer for a couple of minutes.

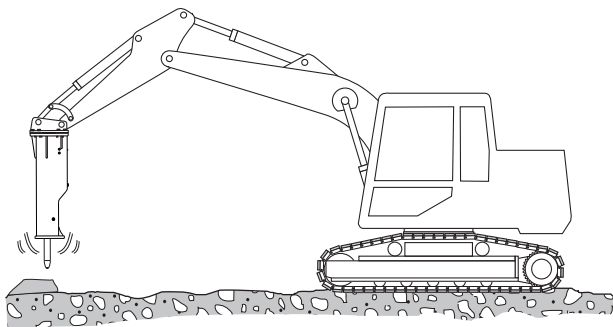

BA010031

LUBRICATION

1. GREASING THE HAMMER

1.1 RECOMMENDED GREASES

For manual tool lubrication use only RAMMER TOOL GREASE, part no. 902045 (400g cartridge), part no. 902046 (18 kg drum), or a grease that meets the following criteria:

- No dropping point or very high, over 250 °C (480 °F).
- Maximum service temperature at least 150 °C (300 °F).
- Minimum working temperature below lowest ambient temperature.
- Additives: molybdenum disulfide (MoS₂), graphite, copper or equivalent.
- Penetration 0 ... 2 (NLGI).
- No reaction with hydraulic oils.
- Water resistant.
- Good adhesion with steel.



Wear gloves when handling the grease containers. If you get grease on your skin, wash it away with water.

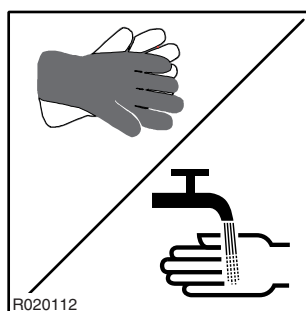

1.2 MANUAL GREASING

NOTICE: During manual greasing, apply down pressure on the tool while the hammer is mounted on the carrier.

Failure to apply down pressure may allow the grease to enter between the tool and the piston. The subsequent impact of the piston on the grease would then generate an extremely high pressure and destroy internal parts of the hammer.

1. With the hammer mounted on the carrier, apply down pressure to the tool in vertical position.
2. Fill the cavity with proper grease. Pump grease into the grease fittings, as indicated on the hammer, to apply a proper amount of grease inside tool bushings. Use an NLGI NO. 2 grease for proper lubrication.
3. Grease at least every three hours of use. In dry applications, such as demolition of concrete, apply grease more frequently. The tool shaft inside the bushing must never be dry!

NOTE: When installing a new tool, liberally coat the upper 1/3 of the tool with grease before inserting.

NOTICE: Failure to comply will cause seizure and excessive wear of the tool and the tool bushing. Excessive wear of the tool bushing misaligns the tool and the piston and will cause severe damage to the interior parts of the hammer. This is considered poor operating practice and not covered by warranty.

2. HYDRAULIC OIL

It is essential that the viscosity of the oil at operating temperature is within specifications. The correct oil viscosity is a guarantee for proper lubrication properties between the piston and the cylinder. Poor viscosity will cause the piston and the cylinder to seize and leads a total failure of hammer internal parts.

For more information see the Operation and Maintenance Manual of the carrier.

Bear in mind that:

- Hydraulic oil degrades quickly in hammer applications and must be replaced more frequently than in digging applications.
- The operating temperature of the hydraulic oil may vary considerably in summer and in winter.
- The plastic parts of the carrier and the hammer, such as seals, have a limit to the temperature at which they perform properly.

Only operate the hammer within the oil temperature range given in specifications.

If the temperature has a tendency to rise above allowed level, reduce heat buildup. The easiest way to do this is to install larger diameter pressure and return lines on the carrier.

If this is not sufficient, install an additional cooler.

NOTE: The warranty will not apply if the seals are miscolored due to overheating.

- Contaminated oil is as dangerous as low viscosity oil. Contaminated oil will also damage the hydraulic pump of the carrier.

Consult your carrier manufacturer on proper filter change intervals and oil change intervals. Follow the instructions and procedures given.

A rule of thumb for special hydraulic fluids, any fluid suitable for the carrier will be suitable for your Rammer hammer. Rammer recommends consulting with your Rammer dealer about changing the hydraulic fluid.

The hammers are test run at the factory with standard hydraulic oil and will have small quantities of oil inside.

Consult your carrier manufacturer for the proper quality requirements (purity, oxidation, moisture) of the hydraulic fluids, whether it be special fluids or hydraulic oil.





MAINTENANCE

1. ROUTINE MAINTENANCE

This Rammer hammer will provide years of trouble-free operation, provided it is properly used and maintained.

Regular hammer inspection and maintenance is essential for keeping the hydraulic hammer operating in the best condition. It is highly recommended that you contact an authorized and trained hammer technician for inspection within six months of original hammer purchase.

1.1 INSPECTION AND MAINTENANCE BY THE OPERATOR

 WARNING	
  	<p>HIGH PRESSURE PINHOLE LEAK HAZARD</p>
	<p>A high pressure jet of hydraulic fluid may penetrate your skin and cause severe injury or death!</p>
	<p>Do not touch fine jets of hydraulic fluid at high pressure. Do not use your fingers to check for hydraulic fluid leaks. Do not put your face close to suspected leaks.</p>

NOTICE: Accumulated grease and oil on a work tool is a fire hazard.

NOTICE: Remove debris with steam cleaning or high pressure water any time a significant quantity of oil is spilled on the hammer.

Before starting the hammer, be sure to inspect the hammer as follows:

- Tighten all loose bolts, nuts and fasteners to proper torque. Replace damaged or missing ones.

Inspect the bracket mounting bolts and tie rods.

- Tighten loose hose and pipe fittings.

Inspect for visible damage to hoses and leakages on hoses and pipes. Check also the hydraulic flanges for proper torque.

Inspect the pipes for the hammer and the oil hoses. If you are using a greasing device, check that as well.

- Hammer oil leaks.

Inspect the connections of the back head and the cylinder.

If leakage occurs at hydraulic hose connections, tighten or replace the fittings.

Other leakages require workshop service. Do not operate the hammer until it has been serviced, as this will cause expensive damage to the internal parts (piston, cylinder).

- Inspect the tool and bushing for abnormal wear and cracks.

Replace the tool when it is worn out.

Inspect the lower tool bushing for wear and replace if required.

Rammer strongly recommends the use of original tools, which are designed to be compatible with internal hammer parts. This is one important means for achieving long service life of the hammer.

- If the hammer is equipped with an automatic greasing device, check that the grease cartridge is not empty. Replace if necessary.

- If the hammer is equipped with an adapter kit for manual greasing, grease the tool each day at startup. Afterwards add 10 pumps every 3 hours using the manual grease pump.

- Inspect the hydraulic oil level and the degree of contamination.

Too little oil may cause an oil heating problem. Contaminated oil will destroy the carrier pump. Follow the instructions of the carrier manufacturer.

- Inspect the hammer body and housing for missing rubber plugs. Replace where missing.

- Check the overall condition of the hammer and the hydraulic system.

Perform all repairs before the hammer is put into service.

- Check safety signs and labels. Replace them when they are damaged, missing, or unreadable.

1.2 INSPECTION AND MAINTENANCE BY THE DEALER

Note: The time intervals refer to the carrier hours while the attachment is installed.

EVERY 600 HOURS OR ONCE A YEAR

This service is recommended to be done by your local dealer after 600 operating hours or at least once a year. Neglecting the annual service can cause severe damage to the hammer.

Your local dealer will reseal the hammer, replace the accumulator membranes and replace safety decals as needed. Contact your local dealer for more information about annual servicing.

During this maintenance you should do the following tasks.

- Check all hydraulic connections.
- Check that the hydraulic hoses do not rub against anything in any boom position.
- Replace and inspect the hydraulic oil filters of the carrier.

2. RELEASING PRESSURE FROM THE HAMMER

**WARNING!**

The hydraulic pressure inside the hammer must always be released before making any adjustments or repairs when the hammer is connected to the carrier. There may also be pressurized oil trapped inside the hammer even if the hammer is disconnected from the carrier. Release the hydraulic pressure according to the following instructions before opening any plugs or valve covers.

1. Stop the carrier engine.
2. Operate the boom and hammer controls to release any pressure trapped inside the hoses.
3. Wait 10 minutes for the oil pressure to drop inside the hammer.
4. Close hammer inlet and outlet lines. If you use quick couplers, the disconnection automatically closes the hammer lines. If the hammer line includes ball valves, make sure that they are closed.

**WARNING!**

This procedure does not release the pressure from the pressure accumulators! Read the instructions for the accumulator before disassembling the hammer.

**WARNING!**

When you are checking or releasing the pressure from the pressure accumulators, use safety glasses and gloves. There might be oil in the accumulator and oil can spray out with the gas.

3. CHECKING PRESSURE IN THE LOW PRESSURE ACCUMULATOR

LOCATION OF ACCUMULATORS

The hammer has one accumulator, a low pressure accumulator (A).

The low pressure accumulator (A) is a piston type accumulator and needs recharging based on specification.

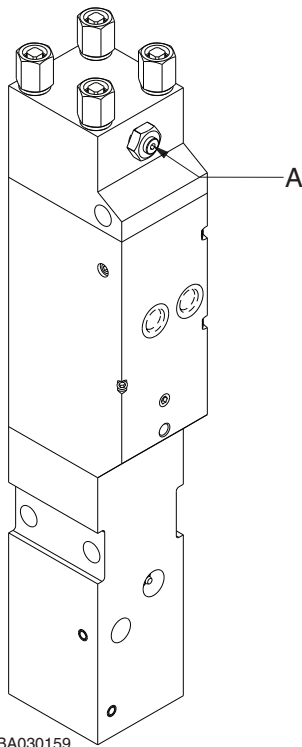

BA030159

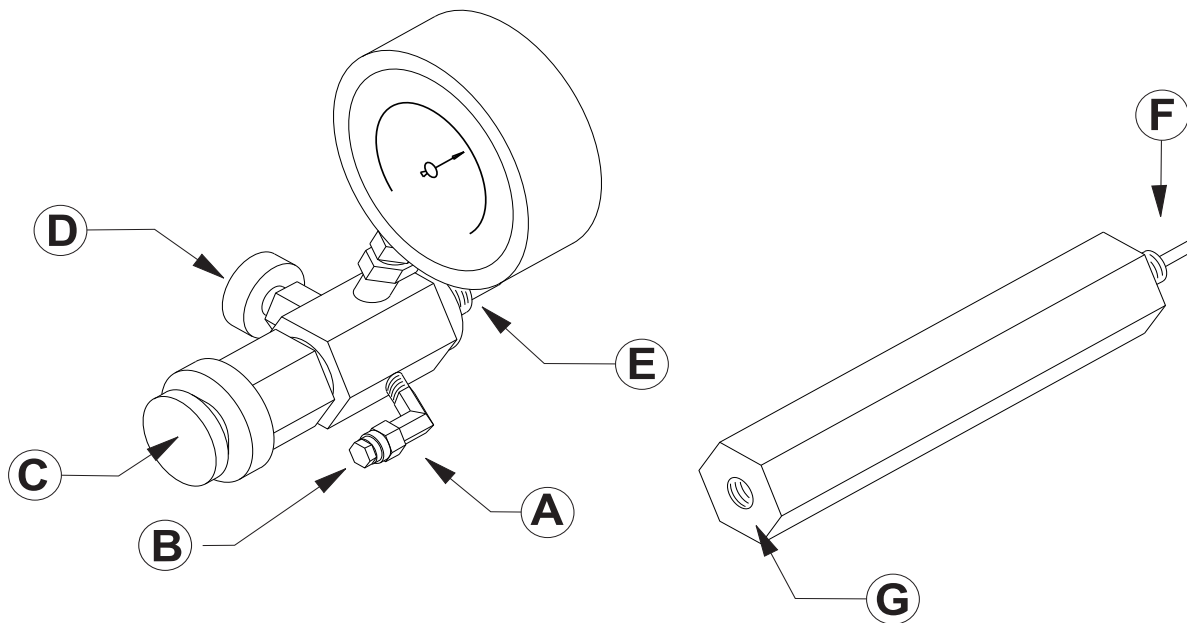



BA030152

Item	Precharge pressure
Low pressure accumulator (A)	13 bar (190 psi)

Item	Torque
Flange plug	10 Nm (7 lbf ft)
Shield plate mounting screws	70 Nm (52 lbf ft)

CHECKING PRESSURE IN THE LOW PRESSURE ACCUMULATOR

 WARNING	
 	<p>HIGH PRESSURE HAZARD</p> <p>Use only Nitrogen (N2) for charging accumulators. The use of other gases may cause accumulators to explode. Failure to comply could result in serious injury or death.</p>

Check pressure in the low pressure accumulator after two weeks.

NOTE: If the low pressure accumulator needs recharging more than once a week, contact an authorized workshop.

NOTE: If oil sprays out from the accumulator when you are inspecting it, service the hammer in an authorized workshop.

1. Place the hammer in a horizontal position with the low pressure accumulator recharging point faced upwards.

During inspection, the piston may move unexpectedly. Make sure the tool is fully extracted and that no people or equipment are near the end of the tool.

2. Remove the shield plate from the housing.

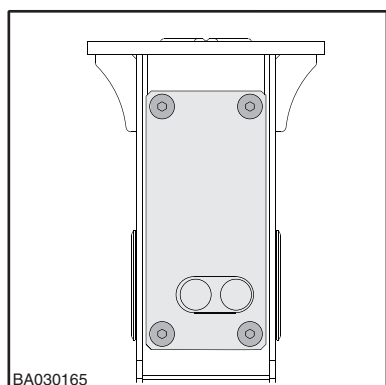

3. Remove the flange plug from the filling plug on the hammer with an Allen key.

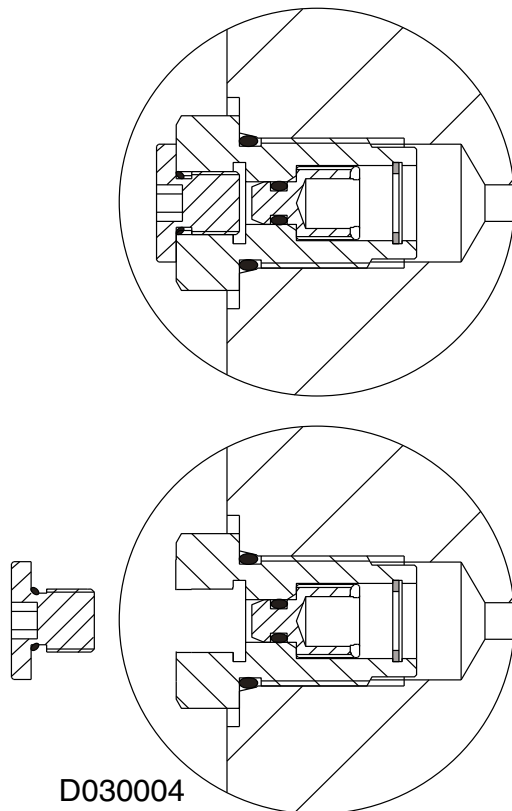

4. Install the cap (B) to the charging device.
5. Pull the handle (C) out and leave it in this position. Close the discharge valve (D) on the charging device by turning the knob.

6. Tighten the recharge valve to the filling plug on the hammer from (E). If the recharge valve does not easily fit to the hammer, first connect the adapter by one end (F) to the hammer and then connect the recharge valve (E) to other end of the adapter (G).

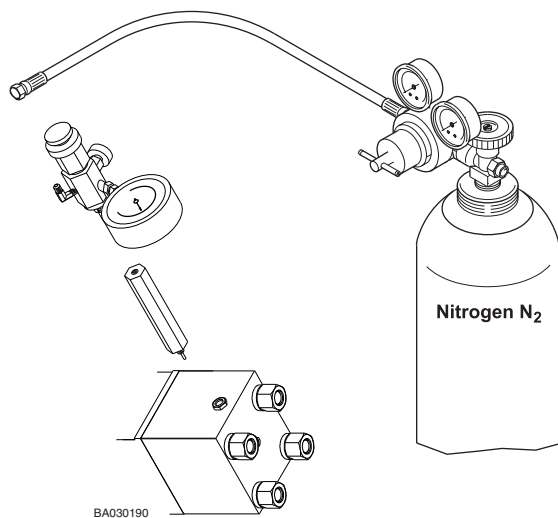

7. Push in the handle (C) on the charging device. Observe the pressure gauge reading on the charging device. If the pressure in the accumulator is not to specification, recharge it so that it is correct.
8. Pull out the handle (C) on the charging device.
9. Open the discharge valve (D) on the charging device by turning the knob.
10. Remove the recharging device from the hammer.
11. Install the flange plug on the filling plug, making sure that no dirt enters the valve. Tighten the flange plug with an Allen key to specified torque.
12. Install the shield plate to the housing and tighten the mounting screws to the specified torque.

4. RECHARGING THE LOW PRESSURE ACCUMULATOR

ACCUMULATOR PRECHARGE PRESSURE

See the precharge pressure on the table in inspection of pressure in the low pressure accumulator.

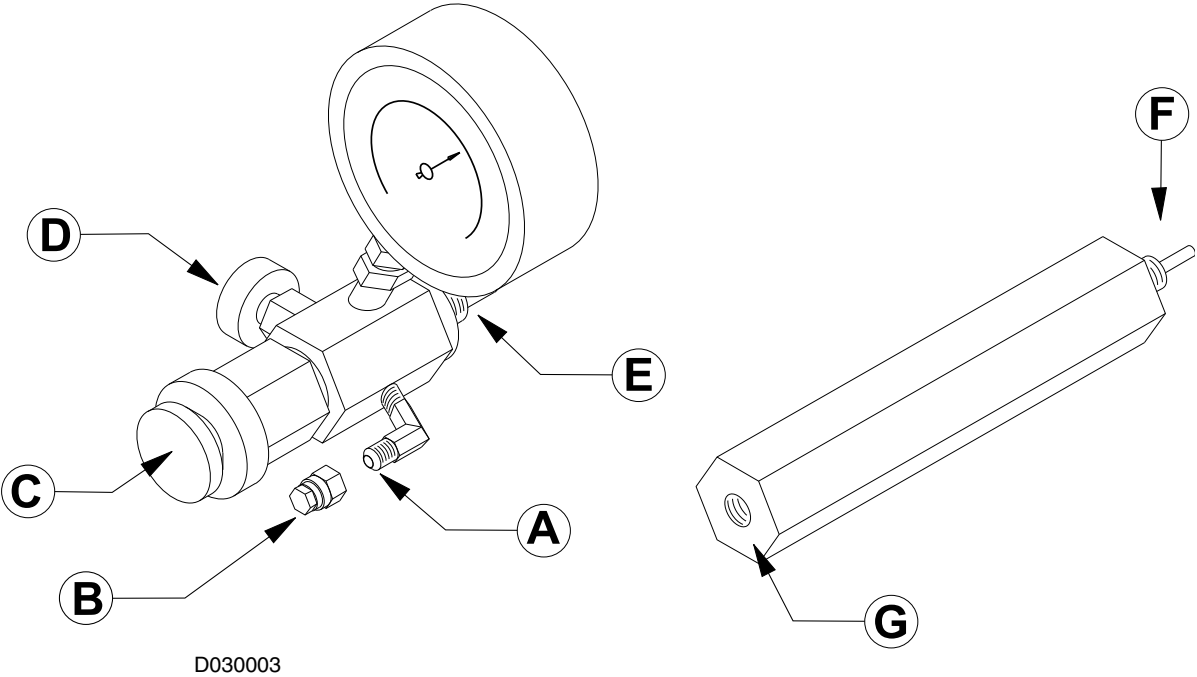

Item	Torque
Flange plug	10 Nm (7 lbf ft)

RECHARGING THE LOW PRESSURE ACCUMULATOR

 WARNING	
 	HIGH PRESSURE HAZARD Use only Nitrogen (N2) for charging accumulators. The use of other gases may cause accumulators to explode. Failure to comply could result in serious injury or death.

1. Place the hammer in a horizontal position with the low pressure accumulator recharging point faced upwards.

During recharging, the piston may move unexpectedly. Make sure the tool is fully extracted and that no people or equipment are near the end of the tool.

2. Remove the shield plate from the housing.

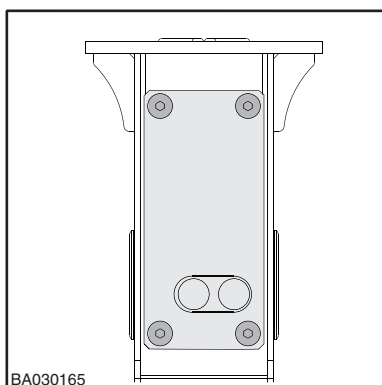

3. Remove the flange plug from the filling plug on the hammer with an Allen key.

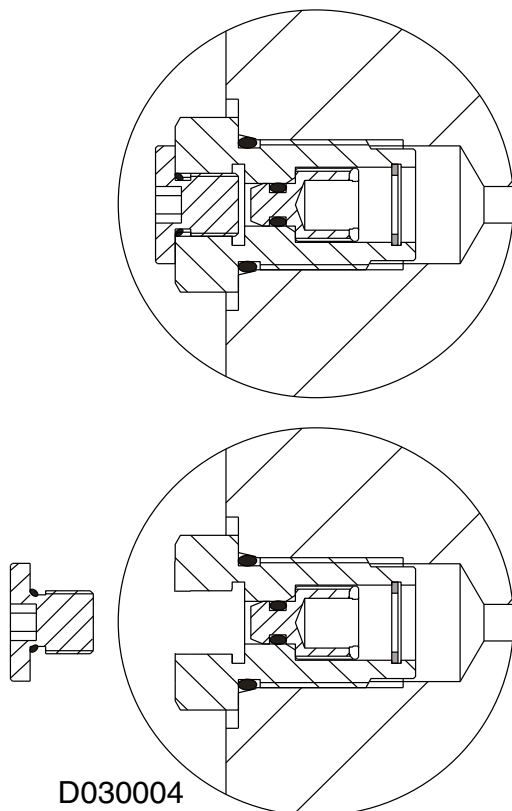

4. Pull the handle (C) out and leave it in this position, otherwise gas leaks out of the accumulator. Open the discharge valve (D) on the charging device by turning the knob.
5. Tighten the recharge valve to the filling plug on the hammer from (E). If the recharge valve does not easily fit to the hammer, first connect the adapter by one end (F) to the hammer and then connect the recharge valve (E) to the other end of the adapter (G).

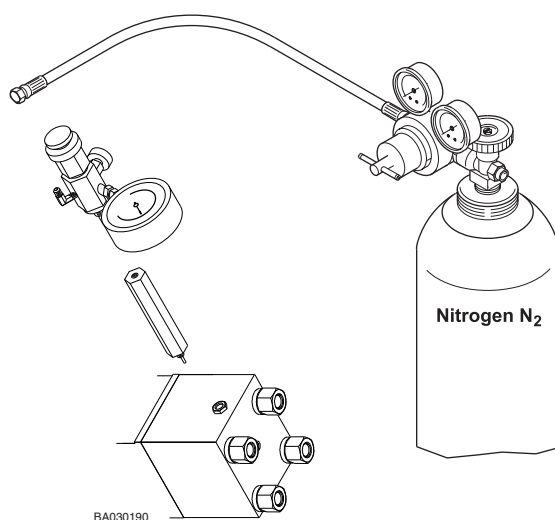

6. Remove the cap (B) from the charging device.
7. Connect the hose of nitrogen gas bottle to charging device at (A).

- Carefully open the valve on the nitrogen bottle and adjust the gas flow to a minimum.

NOTICE: Rapid opening of the valve on the nitrogen bottle may blow the seals in the hammer.

Rapid opening or overcharging may also damage the gauge on charging device.

- Close the discharge valve (D) and push in the handle (C) on the charging device. Charge the accumulator to 2 - 3 bar above the specified charging pressure. Observe the pressure gauge reading on the charging device. **Shut the nitrogen bottle valve.**
- Wait ten minutes for the nitrogen gas pressure to stabilize in the accumulator. If the gas pressure do not stabilized, contact your authorized workshop.
- Adjust the pressure inside the accumulator to the correct setting by carefully opening the discharge valve (D).
- When the proper pressure level is reached, close the discharge valve (D) and release the handle (C).
- Release the nitrogen pressure from the hose by opening the discharge valve (D) on the charging device slowly.
- Remove the recharging device from the hammer.
- Install the flange plug on the filling plug, making sure that no dirt enters the valve. Tighten the flange plug with an Allen key to the specified torque.
- Install the shield plate to the housing and tighten the mounting screws to the specified torque.

5. CHANGING THE TOOL

WEAR LIMITS AND LUBRICANTS FOR TOOL REMOVAL

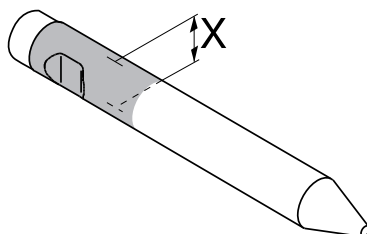

BA030122

Item	Wear limit
Tool diameter (worn out)	51 mm (2.01 in)

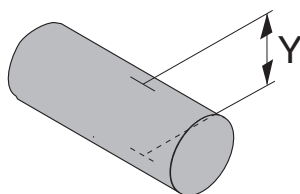

BA030150

Item	Wear limit
Tool retaining pin (worn out)	22 mm (0.87 in)

Item	Lubricant
Tool and tool retaining pins	Tool grease

REMOVING THE TOOL**WARNING!**

The hydraulic pressure inside the hammer must always be released before removing the tool. After operating the hammer, wait 10 minutes for oil pressure to drop inside the hammer.

**WARNING!**

Use caution when you remove the hammer tool. The tool can be very hot after the tool has been in operation. When you remove the hammer tool, wear protective gloves.

1. Position the hammer on level ground.
2. Put the carrier transmission in neutral. Make sure the parking brake is engaged.
3. Stop the engine.
4. Remove the plugs from the hammer housing.

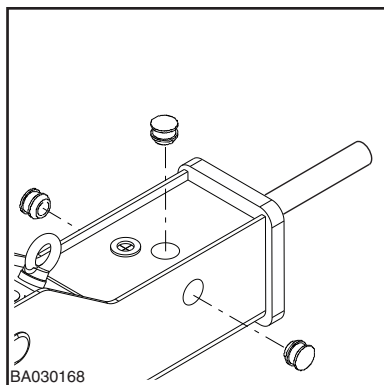

5. Remove the split pin from the front head using the drift pin and the hammer. Wear the protective gloves and approved safety glasses.

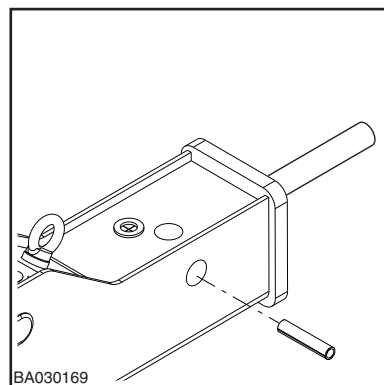

6. Remove the tool retaining pin from the front head using an extraction tool.

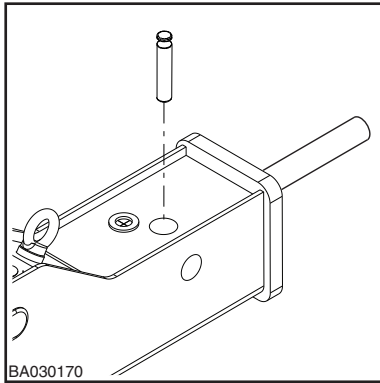

7. Remove the tool. Wear the protective gloves.

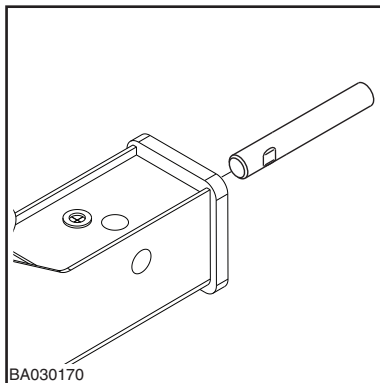

8. If necessary, use a suitable lifting device to remove the tool. Refer to the tool specifications for the weight of the tool. See “Tool specifications” on page 98.
9. Inspect the hammer tool and the lower tool bushing for wear.
10. Refer to specifications for the wear limit for the tool and the lower tool bushings. If you have to replace the lower tool bushing, see the removal and the installation of the lower tool bushing.

INSTALLING THE TOOL

1. Clean the tool.
2. Apply tool grease to the tool.
3. Install the tool.

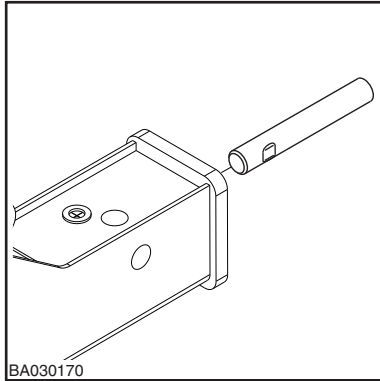

4. Apply grease to the tool retaining pin.
5. Install the tool retaining pin. Wear the protective gloves and approved safety glasses.

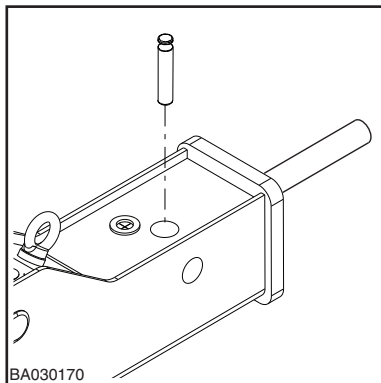

6. Apply grease to the retaining pin.
7. Install the split pin. Wear the protective gloves and approved safety glasses.

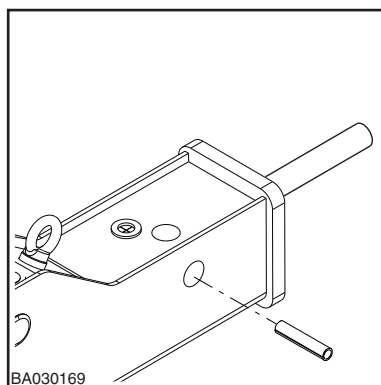

8. Install the plugs to the housing.

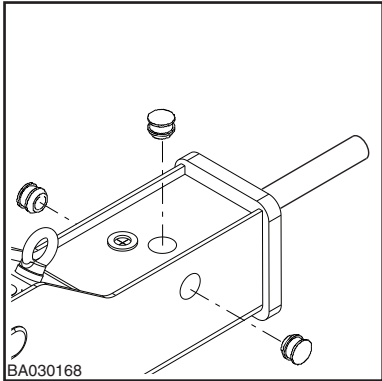

6. CHANGING THE LOWER TOOL BUSHING

WEAR LIMITS AND LUBRICANTS FOR LOWER TOOL BUSHING

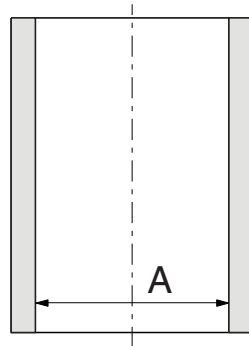

BA030123

Item	Wear limit
Tool bushing inner diameter (worn out)	56 mm (2.20 in)

Item	Lubricant
Contact surfaces of front head	Thread grease

REMOVING AND INSTALLING THE LOWER TOOL BUSHING

Refer to the specifications for the wear limits of the lower tool bushing. If you have to replace the lower tool bushing, contact an authorized workshop.

7. TROUBLESHOOTING

7.1 THE HAMMER DOES NOT START

PRESSURE OR RETURN LINES CLOSED

Check the operation of the quick couplings in the hammer line. Open the hammer line ball valves if closed.

PRESSURE AND RETURN HOSES INSTALLED BACKWARDS

Swap the pressure and return hoses.

PISTON IS IN ITS LOWER HYDRAULIC BRAKE

Keep the hammer control valve open and force the tool against an object. The tool head will push the piston out of its brake area.

GREASE BETWEEN PISTON AND TOOL CONTACT AREA

Remove the tool and wipe excessive grease off.

HAMMER CONTROL VALVE DOES NOT OPEN

When operating the hammer control valve, check that the pressure line pulsates (this indicates the hammer control valve is opening). If the valve does not work, check the means of operation: mechanical connections, pilot pressure or electrical control.

RELIEF VALVE IN HYDRAULIC CIRCUIT OPENS AT A LOW PRESSURE. HAMMER OPERATING PRESSURE IS NOT REACHED

Check the installation. Check the relief valve operation. Adjust the relief valve in hydraulic circuit. Measure the high pressure in the hammer inlet line.

EXCESSIVE BACK PRESSURE IN RETURN LINE

Check the installation. Check the size of the return line.

LEAKAGE FROM PRESSURE TO RETURN IN THE CARRIER HYDRAULIC CIRCUIT

Check the installation. Check the pump and the other hydraulic components.

FAILURE IN HAMMER VALVE OPERATION

Service the hammer at the authorized service shop.

TOO HIGH PRECHARGE PRESSURE OF THE GAS PISTON ACCUMULATOR

Check the precharge pressure and adjust it to a correct value. If oil sprays out from the accumulator, service the hammer at the authorized service shop.

PISTON FAILURE

Service the hammer at the authorized service shop.

7.2 THE HAMMER OPERATES IRREGULARLY BUT THE BLOW HAS FULL POWER

NOT ENOUGH FEED FORCE FROM EXCAVATOR

Refer to the correct working methods.

RELIEF VALVE IN HYDRAULIC CIRCUIT OPENS AT A LOW PRESSURE. HAMMER OPERATING PRESSURE IS NOT REACHED

Check the installation. Check the relief valve operation. Adjust the relief valve in hydraulic circuit. Measure the high pressure in the hammer inlet line.

FAILURE IN HAMMER VALVE OPERATION

Service the hammer at the authorized service shop.

7.3 THE HAMMER OPERATES IRREGULARLY AND BLOW HAS NO POWER

THE WORKING METHOD IS NOT CORRECT

Refer to the correct working methods.

RELIEF VALVE IN HYDRAULIC CIRCUIT OPENS AT A LOW PRESSURE. HAMMER OPERATING PRESSURE IS NOT REACHED

Check the installation. Check the relief valve operation. Adjust the relief valve in the hydraulic circuit. Measure the high pressure in the hammer inlet line.

GAS PRESSURE IN THE GAS PISTON ACCUMULATOR TOO LOW

Check the pressure and fill the gas piston accumulator the correct prefill pressure.

FAILURE IN HAMMER VALVE OPERATION

Service the hammer at the authorized service shop.

7.4 IMPACT RATE SLOWS DOWN

OIL HAS OVERHEATED (OVER +80 °C/+176 °F)

Check for a fault in the oil cooling system or an internal leak in the hammer. Check the hydraulic circuit of the carrier. Check the line size. Assemble an extra oil cooler.

HYDRAULIC OIL VISCOSITY TOO LOW

Check hydraulic oil.

EXCESSIVE BACK PRESSURE IN RETURN LINE

Check the installation. Check the size of the return line.

RELIEF VALVE IN HYDRAULIC CIRCUIT OPENS AT A LOW PRESSURE. HAMMER OPERATING PRESSURE IS NOT REACHED

Check the installation. Check the relief valve operation. Adjust the relief valve in hydraulic circuit. Measure the high pressure in the hammer inlet line.

LEAKAGE FROM PRESSURE TO RETURN IN EXCAVATOR HYDRAULIC CIRCUIT

Check the installation.

GAS PRESSURE IN THE GAS PISTON ACCUMULATOR TOO LOW OR TOO HIGH

Check the pressure and fill the gas piston accumulator the correct prefill pressure.

FAILURE IN HAMMER VALVE OPERATION

Service the hammer at the authorized service shop.

7.5 OIL OVERHEATS

APPLICATION NOT CORRECT FOR HAMMER

Refer to the recommended use and the correct working methods.

THE CARRIER OIL COOLER IS DIRTY

Check and clean the oil cooler.

COOLING CAPACITY OF THE CARRIER OIL COOLER IS TOO SMALL

Assemble an extra oil cooler.

RELIEF VALVE IN HYDRAULIC CIRCUIT OPENS AT A LOW PRESSURE. HAMMER OPERATING PRESSURE IS NOT REACHED

Check the installation. Check the relief valve operation. Adjust the relief valve in hydraulic circuit. Measure the high pressure in the hammer inlet line.

HYDRAULIC OIL VISCOSITY TOO LOW

Check hydraulic oil.

LEAKAGE FROM PRESSURE TO RETURN IN THE CARRIER HYDRAULIC CIRCUIT

Check the installation. Check the pump and the other hydraulic components.

INTERNAL OIL LEAK IN THE HAMMER

Service the hammer at the authorized service shop.

EXCESSIVE BACK PRESSURE IN RETURN LINE

Check the installation.

7.6 RECURRENT TOOL FAILURE

APPLICATION NOT CORRECT FOR HAMMER

Refer to the recommended use and the correct working methods.

ROUGH OPERATING PRACTICES

Refer to the recommended use and the correct working methods.

TOOL DOES NOT GET ENOUGH LUBRICANT

Refer to the recommended use and the correct working methods.

TOOL TOO LONG

Use the shortest tool possible. Refer to the recommended use and the correct working methods.

RAPID WEAR OF TOOL

Refer to the recommended use and the correct working methods.

7.7 FURTHER ASSISTANCE

CONTACT YOUR DEALER

If you need further assistance, have the following information ready when calling your dealer:

- Model and serial number
- Working hours and service history
- Carrier model
- Installation: Oil flow, operating pressure and return line pressure if known
- Application
- Has the product operated normally before?

SPECIFICATIONS

1. HAMMER SPECIFICATIONS

1.1 TECHNICAL SPECIFICATIONS

Description	Specification ¹
Minimum working weight ²	180 kg (397 lb)
Hammer weight	145 kg (320 lb)
Impact rate ³	600...1200 bpm
Operating pressure	75...120 bar (1090...1740 psi)
Pressure relief setting, min ⁴	150 bar (2175 psi)
Pressure relief setting, max	170 bar (2465 psi)
Oil flow range	25...50 l/min (6.6...13.2 gal/min)
Low pressure accumulator, charging pressure ⁵	13 bar (190 psi)
Back pressure, max	20 bar (290 psi)
Input power, max	10 kW (13 hp)
Tool diameter	53 mm (2.09 in)
Pressure line connection (P)	BSPP internal 1/2"
Return line connection (T)	BSPP internal 1/2"
Pressure line size (minimum inner diameter)	12 mm (0.47 in)
Return line size (minimum inner diameter)	12 mm (0.47 in)
Optimum oil temperature	40...60 °C (104...140 °F)
Allowed oil temperature range	-20...80 °C (-4...176 °F)
Optimum oil viscosity at operating temperature	30...60 cSt
Allowed oil viscosity range	20...1000 cSt
Carrier weight ⁶	2...4.4 t (4400...9700 lb)
Skidsteer, Robot weight ⁷	1.4...3.2 t (3100...7100 lb)
Noise level, measured (Directive 2000/14/EC)	112 dB
Noise level, guaranteed (Directive 2000/14/EC)	116 dB

1. Specifications are subject to change without prior notice
2. Including hammer, standard tool and standard bracket.
3. Depends on hydraulic parameters (oil flow and pressure)
4. Operating pressure + 50 bar.
5. At room temperature +20C (68F)
6. Check carrier's lifting capacity, especially with mounting bracket!
7. Check carrier's lifting capacity, especially with mounting bracket!

1.2 MAIN DIMENSIONS:

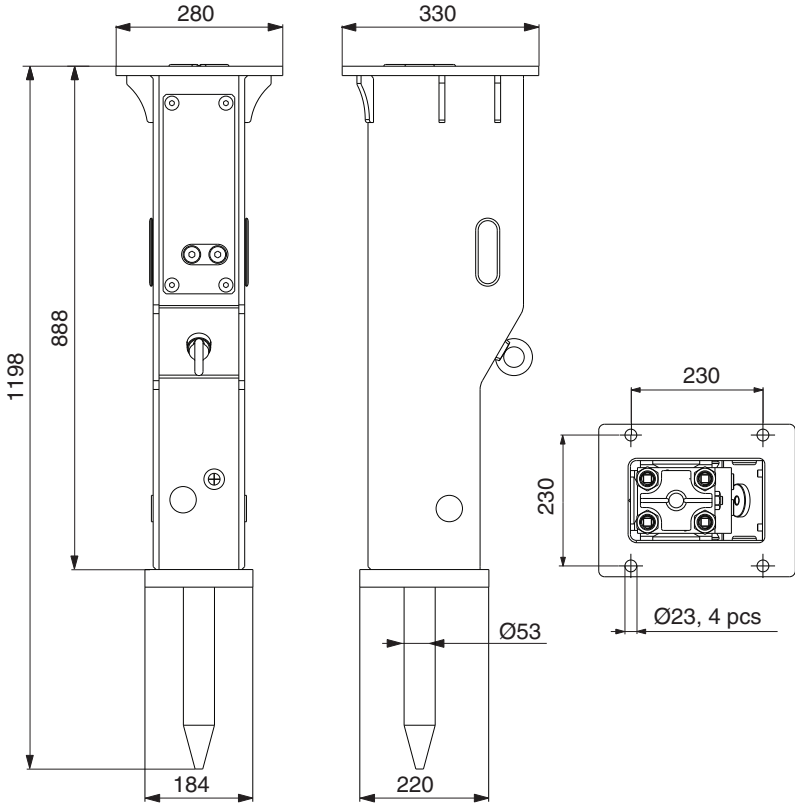

BA040057

1.3 MOUNTING BRACKET

Recommended minimum plate thickness is 20 mm

After welding check flatness of the plate and mill surface as needed. Maximum acceptable deviation from flatness is 1 mm.

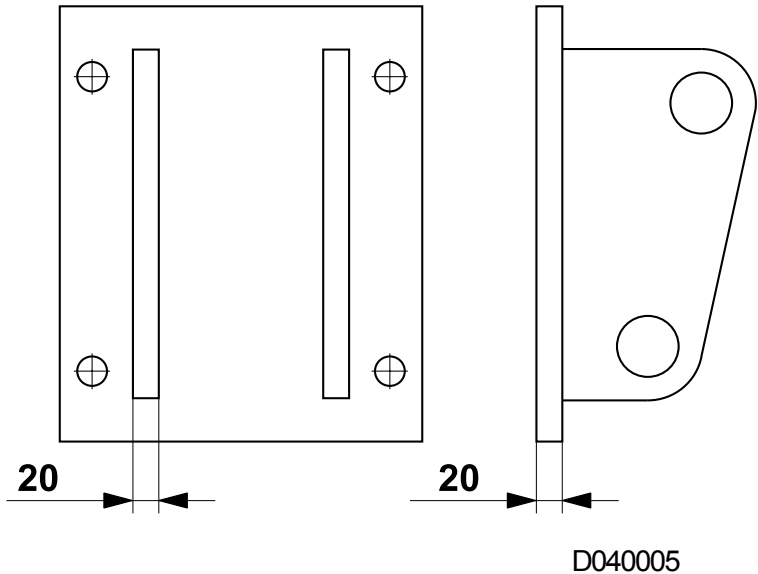

1.4 RD3 TECHNICAL SPECIFICATIONS

BA040069

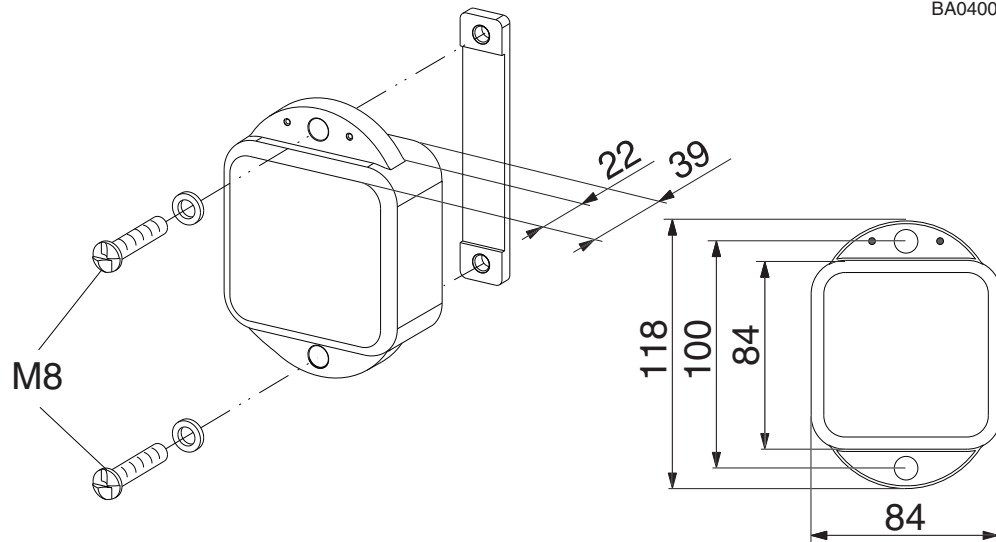

Item	Specification
Battery type	Primary lithium, 7,8 Ah, built-in, encapsulated
Temperature, operating	-20...85 °C (-4...185 °F)
Temperature, storage	-40...85 °C (-40...185 °F)
Antenna, GPS	Internal
Antenna, 3G/GSM	Internal
IP rating	IP69k
ADR	UN3091
Lithium content	2 gram

2. TOOL SPECIFICATIONS

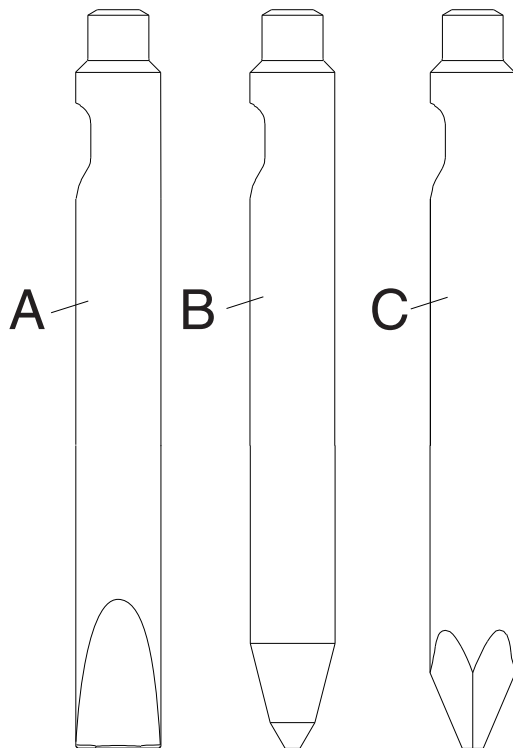

BA040043

Tool	Part no.	Length	Weight	Diameter
Chisel (A)	BK081	580 mm (22.83 in)	9.2 kg (20.3 lb)	53 mm (2.09 in)
Moil point (B)	BK083	580 mm (22.83 in)	8.9 kg (19.6 lb)	53 mm (2.09 in)
Pyramid (C)	BK083K3	580 mm (22.83 in)	9.0 kg (19.8 lb)	53 mm (2.09 in)

3. CE MARK AND EC DECLARATION OF CONFORMITY

3.1 TEXT CONTENTS OF THE EC DECLARATION OF CONFORMITY:

Original

EC DECLARATION OF CONFORMITY

(2006/42/EC, Annex II.1, sub A, Directive 2000/14/EC)

Manufacturer: Sandvik Mining and Construction Oy, Breakers Lahti

Address: Taivalkatu 8, FI-15170 Lahti, Finland

Herewith declares that the Rammer hydraulic hammer

type: **R03P**

- is in conformity with the provisions of the Machinery Directive (2006/42/EC)
- Is in conformity with the provisions of the Noise Directive (Directive 2000/14/EC)

The procedure applied for the Noise Directive Conformity Assessment is "Internal control of production (Annex V)"

TYPE	S/N	Measured sound power level: LWA [dB]	Guaranteed sound power level: LWA [dB]
R03P	03PA	112	116

- **Is in conformity with the relevant provisions of the following other EU directives and regulations, where applicable:**

Radio Equipment Directive 2014/53/EU

Electromagnetic Compatibility Directive 2014/30/EC

- **And the following (parts/clauses of) standards have been applied:**

EN ISO 12100 - Safety of machinery, General principles for design, Risk Assessment and risk reduction

DNV GL certified quality management system according to ISO 9001, Design and manufacture of product

Technical file and manufacturing conformity

N.N., Director R&D/E, is authorized to compile the technical file and confirms the product design to conform with the essential health and safety requirements.

M.M., Director Supply, confirms compliance of the manufactured machinery with the technical file.

N.N. and M.M. are empowered to draw up this declaration of conformity.

Place: Taivalkatu 8, FI-15170 Lahti, Finland

Date: dd.mm.yyyy

Signed: N.N.

Director R&D/E

Signed: M.M.

Director Supply

3.2 RD3 AND DATA PRIVACY

Important notice: This R03P

Hereinafter referred to as the "Product", is equipped with a remote monitoring service device which collects location data and data of usage of the Product (including remote monitoring hardware and software installed, connected, and activated by Sandvik at the factory or otherwise) in order for Sandvik to (i) provide you and Sandvik's distributor/sub-distributor(s) involved in the sale of the Product ("Distributors") with the availability to Product data via a web managed (or similar) subscription service received following online acceptance of www.myhammersfleet.rocktechnology.sandvik/ web portal terms and conditions ("Equipment Monitoring Service"); and (ii) to collect information from the Product in order to monitor the performance, reliability and to track the Product's operational efficiency as well as develop the data. Sandvik reserves the right to anonymize and/or aggregate any data which is created, generated, derived or produced by Sandvik in the Equipment Monitoring Service or otherwise created through the use of the Equipment Monitoring Service, such data never to contain any personal data with the meaning given in the General Data Protection Regulation ((EU) 2016/679), into a new set of data. By using the Product, you consent and agree that Sandvik may generate, collect, record, upload, store, analyse and process standard industry information and data relating to the activity and condition of the Product, including but not limited to location, engine, percussion and /or transmission hours. You agree and acknowledge that Sandvik may use as well as disclose such data to its affiliates or other members within the Sandvik Group, its Distributors and to third parties providing services to the Sandvik Group for optimizing the schedule of its services and parts deliveries and for improving its customer support and/or for any internal purposes, including but not limited to product development, business and marketing analyses and improvement of its products' performance and availability. In the event you wish to withdraw your consent to collect, store and process such data, please request Sandvik in writing to stop collecting and processing such data. A separate three (3) months' advance notice is needed per each unit of Product and shall state at least (i) the serial number of the Product and (ii) the end date of your consent. Please note that if you decide to withdraw your consent, it may affect the validity of the agreements in connection with Product and may lead to the termination of an agreement in accordance with the terms and conditions of the agreement (including but not limited to maintenance agreements and extended warranty agreements). For more information and in order to monitor your own Product, please visit the following web page: www.myhammersfleet.rocktechnology.sandvik/.



Sandvik Mining and Construction Oy, Breakers Lahti
Taivalkatu 8, P.O. Box 165, FI-15101 Lahti, Finland
Phone Int. +358 205 44 151, Telefax Int. +358 205 44 150
www.rammer.com