

RAMMER R18P



PROVEN TECHNOLOGY

PERFORMANCE LINE



RD3 remote monitoring system now available as an option

VIBRATION AND SOUND SUPPRESSED

IDLE BLOW PROTECTION (FIELD ADJUSTABLE ON/OFF)

RAMLUBE II GREASING SYSTEM

EXCELLENT POWER-TO-WEIGHT RATIO

NITROGEN PISTON ACCUMULATOR

PRESSURE DAMPENING MEMBRANE ACCUMULATOR

QUICK CHANGE TOOL SYSTEM

EASY TO SERVICE



UNBEATABLE PERFORMANCE

The new Rammer Performance Line hammers are your everyday solution for a wide range of breaking demands. Designed with proven Rammer features and standards, these Rammer Performance Line hammers offer more than just excellent power-to-weight ratio, they bring the quality reassurance that only a true Rammer hammer can bring.

Read more about the product from www.rammer.com

Rammer[®]

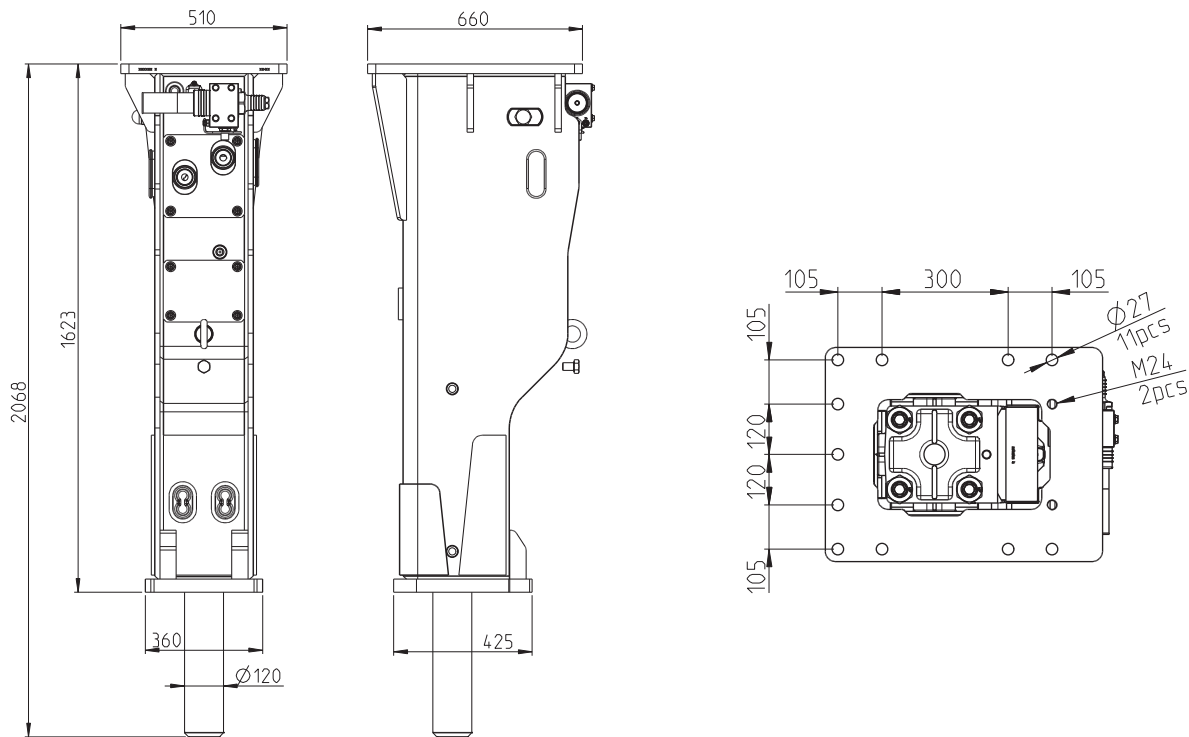

ACCESSORIES



Ramlube II

Lubrication system for optimum wear and impact protection.



RD3

RD3 remote monitoring system gives you detailed information about the operating hours, service intervals and GPS location of your product.

| | |
|--|---------------------------|
| Min. working weight, kg (lb) | 1 240 (2 730) |
| Tool diameter, mm (in) | 120 (4.72) |
| Oil flow range, l/min (gal/min) | 100 - 140 (26.4 - 37) |
| Impact rate, bpm | 280 - 760 |
| Operating pressure, bar (psi) | 160 - 180 (2 320 - 2 610) |
| Pressure relief, min, bar (psi) | 200 (2 900) |
| Pressure relief, max, bar (psi) | 220 (3 190) |
| Back pressure, max, bar (psi) | 10 (145) |
| Input power, kW (hp) | 42 (56) |
| Carrier weight, allowed range, t (lb) | 15 - 23 (33 100 - 50 700) |
| Noise level measured sound power level, LWA, dB(A) | 119 |
| Noise level guaranteed sound power level, LWA, dB(A) | 123 |

TOOLS

